

3.7QT Air Fryer Instruction Manual

View this product on [decogear.com](https://www.decogear.com)

Model No.: DGAF01

TABLE OF CONTENTS

Important Safeguards	02
Getting to Know Your Air Fryer Diagram	04
Before First Use	06
Using Your Air Fryer	06
Usage Notes	08
Cleaning And Maintenance	08
Food Table	09
Troubleshooting	10
Technology specifications	10

Manufacturer's 1-Year Limited Warranty

The manufacturer warrants that all parts and components are defect free in materials and workmanship for 1 year. This warranty is valid only in accordance with the conditions set forth below:

1. The warranty extends only to the original consumer purchaser and is not transferable. In addition, proof of purchase must be demonstrated.
2. This limited warranty is the only written or express warranty given by the manufacturer. Any implied warranty of merchantability or fitness for a particular purpose on this product is limited in duration to the duration of this warranty. Some states do not allow limitations on how long an implied warranty lasts, so the above limitation may not apply to you.
3. This warranty gives you specific legal rights. You may also have other rights which vary by state

Procedure for Replacement or Return within the 1 Year:

To return the product for replacement or refund within the 1 year, the original purchaser must pack the product securely and send it postage paid with a description of the reason for replacement or refund, proof of purchase, and include your order number on the package, to the following address:

Deco Chef
80 Carter Drive
Edison, NJ 08817

Important safeguards Please retain these instructions for future reference.

1. Read all instructions before using.
2. Do not touch the hot surfaces. Use handles.
3. To protect against electrical shock and affecting the function, do not immerse the appliance, body, cord, or plug in water or other liquid.
4. Close supervision is necessary when any appliance is used by or near children.
5. Unplug from outlet when not in use and before cleaning. Allow to cooling before Putting on or taking off parts, and before cleaning the appliance.
6. Do not operate Buffet Server with a damaged cord or plug or after the appliance malfunctions or has been damaged in any manner. Return the appliance to the nearest authorized service facility for examination, repair or adjustment.
7. The use of accessory attachments not recommended by the appliance manufacturer may result in fire, electric shock or injuries.
8. Do not use outdoors.
9. Do not let cord hang over edge of table of counter, or touch hot surfaces.
10. Do not place the appliance in the presence of explosive and/or flammable fumes.
11. Do not move the appliance when the appliance is contained with food, hot oil or other hot liquids.
12. Do not use the appliance for other than intended use.
13. To disconnect, press "Ⓢ" button, then remove plug from wall outlet.
14. Be sure to use on a heat resistant and even surface. Keep at least 15 cm away from walls and other flammables.
15. Notice that the tray only can put food or liquid at the 2/3 of capacity.
16. Before the appliance stops working, the heater surface keeps warm a long

time. Do not touch the surface before cooling.

17. Do not operate the appliance without any things, or else the body is easy to change shape

18. CAUTION: TO REDUCE THE RISK OR ELECTRIC SHOCK. COOK ONLY IN THE PROVIDED REMOVABLE CONTAINER.

19. CAUTION: Hot surface

20. CAUTION: to ensure continued protection against risk of electric shock, connect to properly grounded outlets only

21. when the appliance provided with a flexible cord less than 4-1/2 feet (1.4m) in length, the extension cord should be a grounding-type 3-wire cord and meet the following requirements:

1) a short power-supply cord should be used to reduce the risk resulting from becoming entangled in or tripping over a longer cord.

2) longer extension cords are available maybe used if care is exercised in their use.

3) If a longer extension cord is used:

a) the marked electrical rating of the extension cord should be as great as the electrical rating of the appliance

b) the cord should be arranged so that it will not drape over the countertop or tabletop where it can be pulled on by children or tripped over unintentionally.

This appliance is intended for Household Use Only

Getting to know your air fryer

Your Air Fryer uses rapid 360° air circulation technology to cook with little to no oil, for quick, crispy, delicious food. With user-friendly, one-touch controls and an intuitive, safe design, the Air Fryer is the star of your kitchen.

Diagram

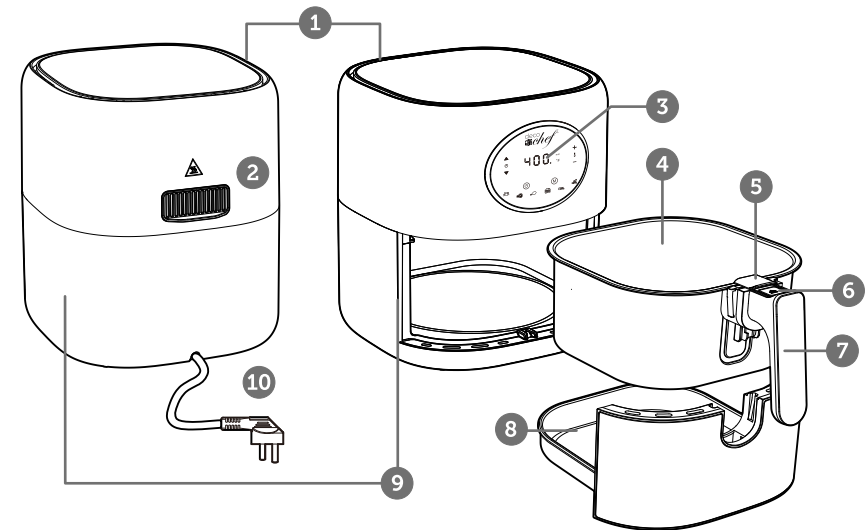

- | | |
|---------------------|--------------------------|
| 1. Air Inlet | 6. Basket Release Button |
| 2. Air Outlet | 7. Handle |
| 3. Control Screen | 8. Pan |
| 4. Basket | 9. Body |
| 5. Protective Cover | 10. Power Cord |

Diagram

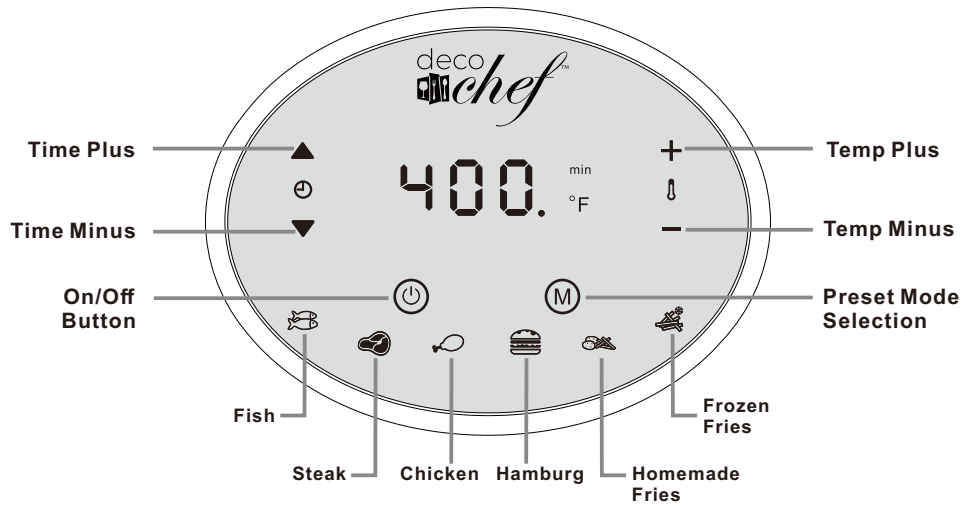

1. There are 6 menu options, each with a preset time and temperature.
2. Press (M) once. The Fish icon will illuminate. Press (M) to advance to the next menu option.

Food Preset Modes Guide		
Food	Preparation Time	Temperature (°F)
Fish	22 mins.	395° F
Steak	18 mins.	385° F
Chicken	25 mins.	355° F
Hamburger	17 mins.	320° F
Home-made fries	26 mins.	355° F
Frozen fries	18 mins.	385° F

ON/OFF Button: Unit will turn off 20 seconds after pressing this button. You do not need to unplug the unit to turn it off.

Please allow approximately 30 minutes after shut-off for the air fryer to cool down.

Before First Use

- 1 Remove all packaging from the air fryer, including any temporary stickers.
- 2 Thoroughly wash all parts by hand with hot water, washing-up liquid and a non-abrasive sponge.
- 3 Wipe the inside and outside of the appliance with a moist cloth.
- 4 Dry all parts of your Health Fryer thoroughly. When replacing the Drawer, ensure it is aligned correctly.
- 5 Use the appliance on a horizontal, flat and stable heat resistant surface, away from a heating source and where it cannot be splashed by water.
- 6 Leave 10cm of space behind and above the air fryer. Leave enough room to remove the baskets.

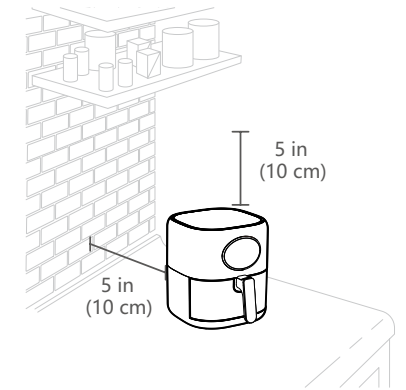

Using Your Air Fryer

- 1 Plug in. The On/Off button (power icon) will illuminate.

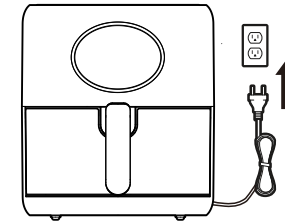

- 2 Place ingredients in the mesh basket. Make sure the basket is well-inserted into the pan. **NOTE: Do not fill the basket more than half full.** Slide pan back into air fryer and make sure it is securely in place.

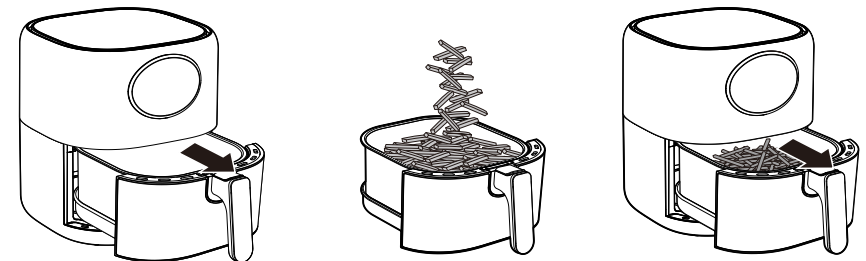

- 3** Set temperature control to desired temperature, and the timer to the desired cook time.
- You can also use one of the preset shortcut functions, and adjust as needed with the timer and temperature buttons.

NOTE:

- To easily increase or decrease time or temperature, press and hold the ▲ ▼ + - buttons.
- Time Control Buttons enable you to select exact cooking time to the minute, from 1 min. to 60 mins. in all modes except when dehydrating, which uses 1 hr. intervals and an operating time of 2-24 hrs.
- A larger amount of ingredients requires only a slightly longer frying time, a smaller amount of ingredients requires only a slightly shorter frying time.
- A larger amount of ingredients requires only a slightly longer frying time, a smaller amount of ingredients requires only a slightly shorter frying time.
- When you have chosen a preset shortcut function, it will start cooking automatically if you do not touch any buttons in 5 seconds.

Press the  to start cooking.

NOTE: You can change the time and temperature during cooking.

Once you are familiar with this air fryer, you may want to experiment with your own cooking times and temperatures.

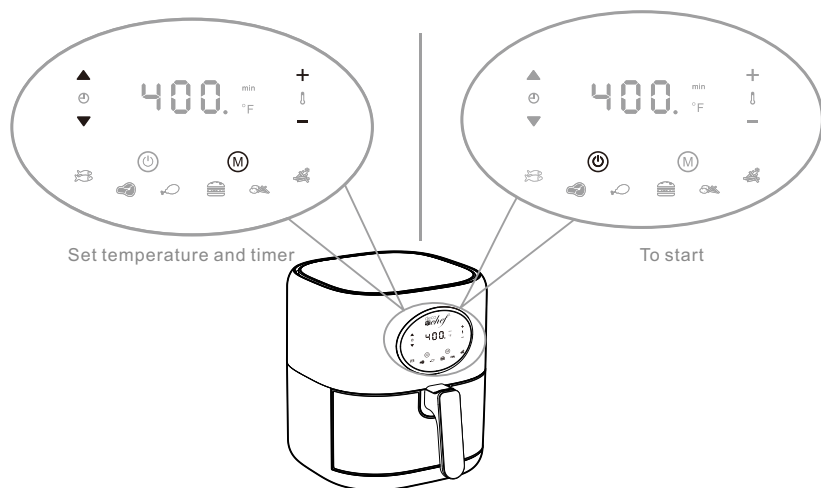

- 4** For certain foods, you may want to shake the pan or flip the food during the frying process.

- Pull the pan out of the appliance to shake the food.
- Do not push the button of the handle.
- Put the pan back into the unit, It will continue cooking automatically.

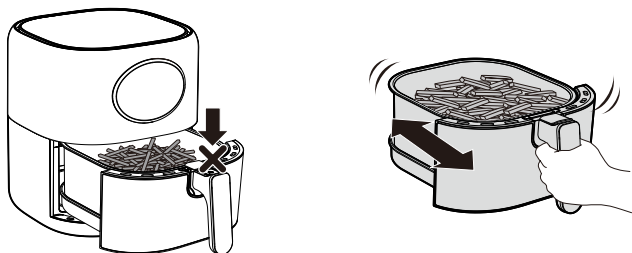

- 5** When the time is up on the timer, the air fryer will beep and automatically turn off.

Carefully pull out the pan.

Press the button to release the basket.

NOTE: Make sure to place the basket on a stable surface away from any combustible items.

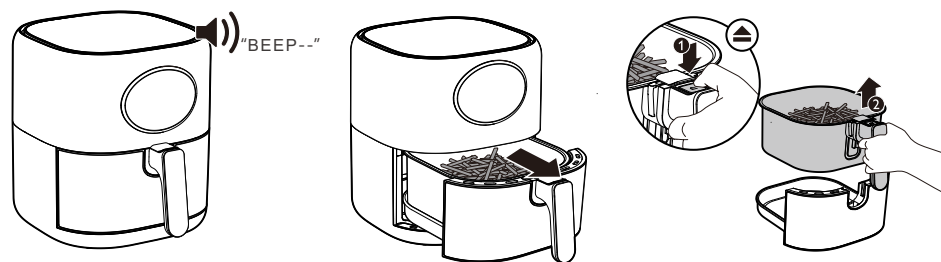

Usage Notes

- Shaking foods placed in the air fryer during cooking can help prevent uneven cooking.
- Do not cook overly greasy foods in the air fryer.
- You can use a light amount of oil to make food crispy, but do not add an excessive amount of oil.
- Please use a baking tin or oven dish inside the basket if you wish to bake cakes, quiche or stued/fragile ingredients.
- Always unplug the appliance when you are done cooking with it. Do not move or store the appliance until it has completely cooled down.

Cleaning And Maintenance

- Always clean the air fryer after it has cooled down completely.
- Unplug the air fryer before cleaning.
- Do not use a strong, corrosive cleaner to clean this appliance.
- Use a soft, clean cloth to wipe down air fryer. Do not use a wet cloth.
- Do not clean the pan, basket, and inside of appliance with metal kitchen utensils or abrasive cleaning materials or you could damage the protective coating.
- Clean pan and basket with normal water, some dish washing liquid, and a non-abrasive sponge. Pan and basket are also dishwasher safe.

Food Table

The table below helps you select the basic setting for the types of food you want to prepare. Keep in mind that these settings are suggestions. As ingredients differ in origin, size, shape, and brand, we cannot guarantee the best settings for your ingredients. When preparing larger amount of food (e.g. fries, prawns, drumsticks, frozen snacks) shake, turn, or stir the ingredients in the basket 2 to 3 times in order to achieve a consistent result.

Food	Time (min.)	Temperature (°F)	Shake/Flip	Additional Info.
Thin Frozen Fries	15-20	390	Shake	
Thick Frozen Fries	11-25	390	Shake	
Homemade Fries(8x8mm)	20-28	390	Shake	Add ½ tbsp. oil
Homemade Potato Wedges	20-30	390	Shake	Add ½ tbsp. oil
Hash Browns/Rösti	15-18	360	Shake	Add ½ tbsp. oil
Steak/ Pork Chops	10-20	375	Flip	
Fish	15-20	375	Flip	
Hamburger	15-20	320	Flip	
Sausage/Hot Dog	13-15	380	Flip	
Chicken Drumsticks	20-30	365	Flip	
Chicken Wings	16-20	400	Flip	
Chicken Breast	15-25	365	Flip	
Frozen Chicken Nugget	10-15	400	Shake	
Root Vegetables	10-15	360		
Cakes	20-30	320		Use baking tin
Frozen Onion Rings	15-18	400	Shake	

Troubleshooting

Problem	Reason	Solution
Air fryer does not work	Appliance is not plugged in correctly	Plug into grounded wall outlet
	Timer/mode is not set	Set timer/mode and press ON/OFF to start the air fryer
	Pan is not well-inserted	Pull pan out and re-insert
Ingredients fried by fryer are not done	Too many ingredients in basket	Place smaller batches in fryer; smaller batches cook quicker and more even
	Set temperature is too low	Raise temperature
Ingredients are fried unevenly	Large batches of ingredients and ingredients that lay on top of each other can cook uneven	Certain ingredients should be shaken halfway through cooking
	Ingredients are not fresh or prepared properly	Make sure to use fresh ingredients, and prepare them correctly for frying (such as rinsing potatoes of starch)
Fried snacks are not crispy when they come out of the fryer	Certain ingredients are better for air frying	Lightly brush some oil onto snacks or use oven-ready snacks in air fryer
Pan will not slide into air fryer correctly	Too many ingredients in basket	Do not overload ingredients in the basket
	Basket not placed into pan correctly	Push basket into pan until it makes a click
White smoke comes out of appliance	Food in air fryer is greasy	White smoke is normal when frying greasy food in air fryer and should be OK
	Pan still contains grease residue from previous use	Make sure you properly clean the pan after each use

Technology specifications

Dimensions	32 x 26 x 29 cm
Weight	3.9 kgs
Rated Voltage	120V
Rated Frequency	60Hz
Rated Power	1200W
Timer	0-60 min
Temperature Range	175-400°F
Capacity	3.7 QT