

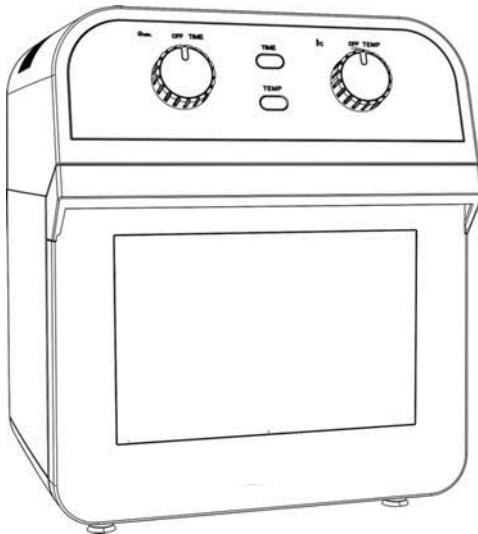

## OVEN AIRFRYER



ITEM#: DCOVENAIRBLK

Please keep this instruction carefully

Please read the manual and relevant notes carefully before using

[View this product on decogear.com](http://decogear.com)



## ▲IMPORTANT SAFEGUARDS TIPS

### Danger

- Do not immerse the power cord, plug or housing in water or under the tap during cleaning, to avoid any danger.
- Avoid any liquid enter the appliance to prevent from electric shock or short-circuit.
- Do not cover the air vents and plug base of the appliance during working.
- Some parts of the appliance have high temperature during operation, e.g.mesh basket, wire rack, drip tray, etc. Please use the handle,tong or glove instead of hand touching directly.

### Warning

- Make sure that your output voltage corresponds the voltage stated on the rating label of the appliance.
- Before using, please check the power cord of appliance and the accessories, do not use with any damage.
- This appliance is not intended for use by persons(including children) with reduced physical, sensory or mental capabilities, or lack of experience and knowledge, unless they have been given supervision or instruction concerning use of appliance by a person responsible for their safety.
- Do not let cord hang over the sharp edge of counter.
- Do not plug in the appliance or operate the control panel with wet hands.
- Do not place or use the appliance on or near combustible materials, such as tablecloth, curtain or wallpaper, in order to avoid something burning.
- External power cord connection is not allowed.
- High temperature in fryer inner chamber during operation, please do not put plastic dishes, bowls or protection film into it.
- The appliance should be placed on a horizontal and stable surface when using. Do not place on plastics, board or any other hot-short, easy-wear surface.
- Do not place the appliance against wall or other appliances, all around 10cm of space required to remain.
- Do not place anything on the top of appliance.
- Do not use the appliance beyond the specification of this manual.
- Do not use this product in the unattended.
- During the appliance frying, hot steam will exhaust through the hind side air outlet.Keep your hands and face at a safe distance from the steam and the air outlet openings.Also be careful of hot steam and air when you remove accessories from the appliance.
- Once cooking done and taking the accessories out, the heater accessories are with very high temperature. Do not touch them.
- If the preset time is too long, the food will be burnt and smokes and would release from air outlet, Plug off immediately and clean the food and oil of the

mesh basket, wire rack and drip tray.

- After using the air fryer, please turn the knobs to OFF position, then pull the plug from the socket, avoid pulling power cord strongly and directly.
- If the supply cord is damaged, it must be replaced by the manufacturer, its service agent or similarly qualified persons in order to avoid a hazard.
- This appliance can be used by children aged from 8 years and above and persons with reduced physical, sensory or mental capabilities or lack of experience and knowledge if they have been given supervision or instruction concerning use of the appliance in a safe way and understand the hazards involved. Children shall not play with the appliance. Cleaning and user maintenance shall not be made by children unless they are older than 8 and supervised.
- Keep the appliance and its cord out of reach of children less than 8 years.
- Appliances are not intended to be operated by means of an external timer or separate remote-control system.
- The door or the outer surface may get hot when the appliance is operating.

### **Caution**

- Always unplug the appliance from outlet when it is not in use or before cleaning. Allow it to cool down first. And then make cleaning.
- Do not use any accessories provided by non-native.
- This appliance is intended to be used in household. Do not use outdoors.
- Clean and wipe dry the mesh basket, wire rack and drip tray, before putting the food inside.
- The appliance has a built-in safety switch. Only when the cooking window component propulsion in correct place, it can be switched to standby mode.

## ▲PRODUCT STRUCTURE DIAGRAM

### Product Components:

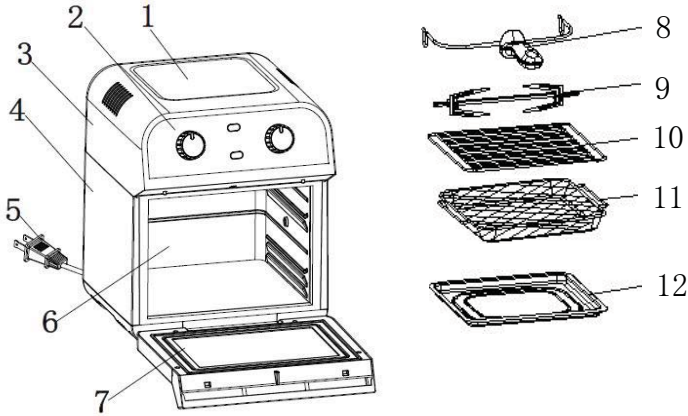

1. Top cover	7. Door
2. Control panel	8. Rotisserie Tong
3. Upper cover	9. Chicken fork
4. Housing	10. Wire rack
5. Power cord	11. Mesh basket
6. Inner case	12. Drip tray

### Intelligent control panel:

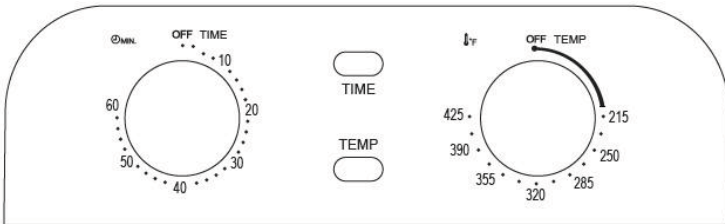

## BEFORE FIRST USE

1. Remove all packaging materials, stickers and labels.
2. Clean the mesh basket and all other accessories with hot water, dishwasher liquid, and a non-abrasive sponge.
3. Wipe the inside and outside of the appliance with a cloth.

## ▲ PRODUCT USAGE INSTRUCTIONS

1. Place the appliance on a stable, horizontal and level surface. Leave at least 10cm free space on the back and sides, and pay attention away from curtains, wall covering and other combustible materials.
2. After opening front door, the drip tray should be pushed into the unit for gathering fried oil in which controlling the drip tray go along the guiding step that built on both side of inner wall of the unit. As shown in the figure below:

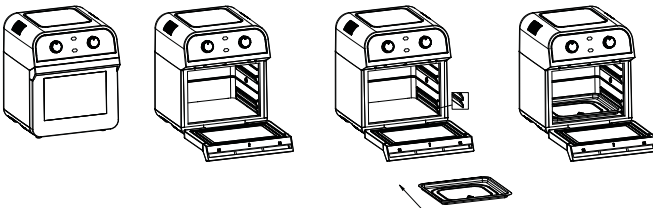
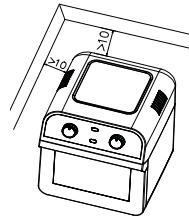

3. Then insert the wire rack, rotisserie fork or mesh basket in along the guiding step that built on the same inner wall. As shown in the figure below:

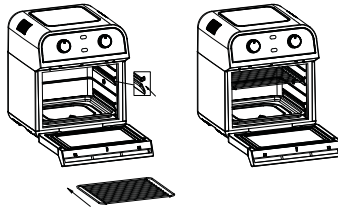

4. Use the tong to take the rotisserie fork into the inner chamber or out of inner chamber.



**Note:**

- \*Choose proper accessories for different cooking.
- \*Please use the GLOVE to take out the wire rack or drip tray after cooking finished.
- \* Please always keep the drip tray stay in the lowest layer for gathering oil from fried food.
- \* Do not let food exceed the MAX position. If the ingredients may become bigger after heating, count the amount according to the heated volume.
- \* There is a Safety switch as shown in the picture on the right:
- \*Only when the front door closed and the machine can work properly.

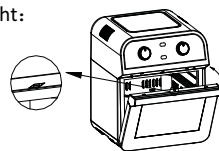

## ▲ PRODUCT OPERATING INSTRUCTIONS

### TIME/TEMP

Put the plug into outlet, and turn “TIME/TEMP” knob, the appliance is ready to work.

### Menu function selection

We have provided different combinations of cooking time and temperature to satisfy your different cooking way.

Turn “TIME/TEMP” knob, the appliance will start. Easy Operate !

Below is our menu combination, at the same time, you can change the time and temperature according your actual situation.

Fries	425°F	25 ~30mins
Frozen Food	180°F	10~15mins
Wings	390°F	15~20mins
Dehydrate	160°F	8 hour
Steak	355°F	12~15mins
Chips	425°F	20~25mins
Fish	355°F	15~18mins
Vegetables	355°F	12~15mins

Popcorn	425°F	8~12mins ( Need to preheat for 2 minutes )
Chicken	425°F	25-35mins
Cake	355°F	30~35mins
Skewer	390°F	15~20mins
Pizza	355°F	15~20mins
Keep Warm	180°F	30mins
Toast	390°F	3~6mins
Cookie	355°F	12~15mins

**Note:** The larger the size of roasted chicken or food, the more time and temperature it will take, cook the food according to the actual situation.

### Setting of cooking time and temperature

When turn the Temp knob or Time knob to your desired the temperature/Time,it start working.

Turn the Temp knob to your desired temperature, “temp”  green light on. Then

turn the Time knob to your desired time, “Time”  red light on. Two lights on means the appliance is working. Time can be chosen from 10-60mins, Temperature can be chosen from 215-425 ° F.

### Pause function

During cooking, the appliance will stop automatically as long as you open the door. When close the door, the appliance will continue the previous cooking work.

**Tip:**

During cooking, turn the food regularly or irregularly to help cook more evenly and cook better.

**Note:** During cooking, mesh basket, loaves,wire rack and drip trays are very hot and cannot be touched directly by hand.



## Rotating function

1. This function can make food heat more evenly. The scroll cooking mode is the default.
2. Usage of roasted chicken forks is as shown below:

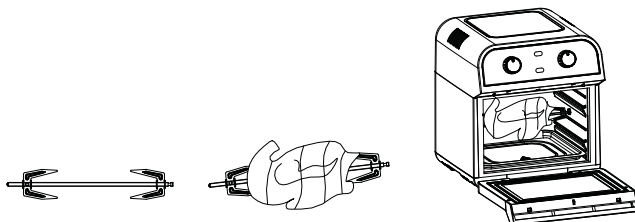

### Note:

The total weight of chicken should not exceed 2.7lb. If the weight is more than 2.7lb, please use the frying basket, because the big chicken will touch the drip tray when rotating.

The position where the chicken legs and wings open should be bound with something.

It is better to make a few holes with needle in the chicken legs when bake, because the meat of the chicken legs is thick and the heat is difficult to penetrate.

## Finish cooking

1. When finish cooking, the timer will make a sound "ding" , the appliance stops working.
2. Open the front door, then remove the accessories from the inner chamber, and put it in a safe horizontal place.

**Note: when removing the accessories from the appliance, do not touch the accessories with your hands.**

**Tip: If the food looks not very good after cooking, put the accessories back again into the inner chamber, just take a few more minutes of cooking again.**

3. Pour cooked food on a plate or tableware. As shown below:



4. After cooking , turn the knobs to OFF position to turn off the power supply and unplug the power cord from the wall.

## ▲Cleaning and maintenance

**Note:** Be sure to unplug this appliance before cleaning.

- ✧ Clean the mesh basket, wire rack, drip tray, rotisserie fork with water or washing-up liquid after using.
- ✧ Wipe the appliance with soft moist cloth. No washing-up liquid.
- ✧ Don't immerse the power cord, plug and the appliance body in water or other liquid, it may result in damage, fire, electric shock or injury to persons.
- ✧ After drying, assemble all parts and keep for next use.

## ▲Appendix1

Circuit principle diagram

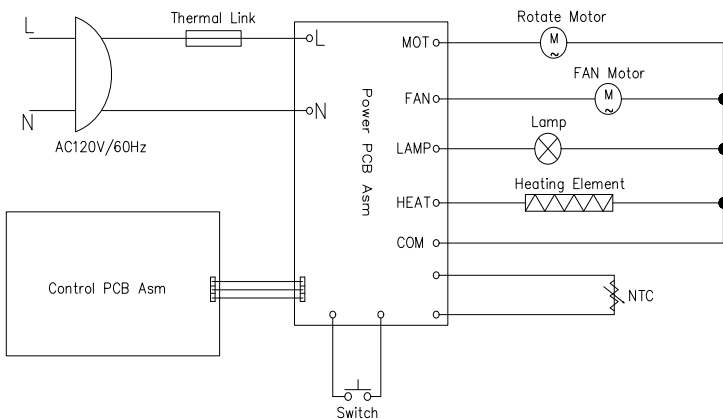

This product must not be disposed together with the domestic waste. This product has to be disposed at an authorized place for recycling of electrical and electronic appliances. By collecting and recycling waste, you can help to save natural resources, and make sure the product is disposed in an environmental friendly and health way.

