

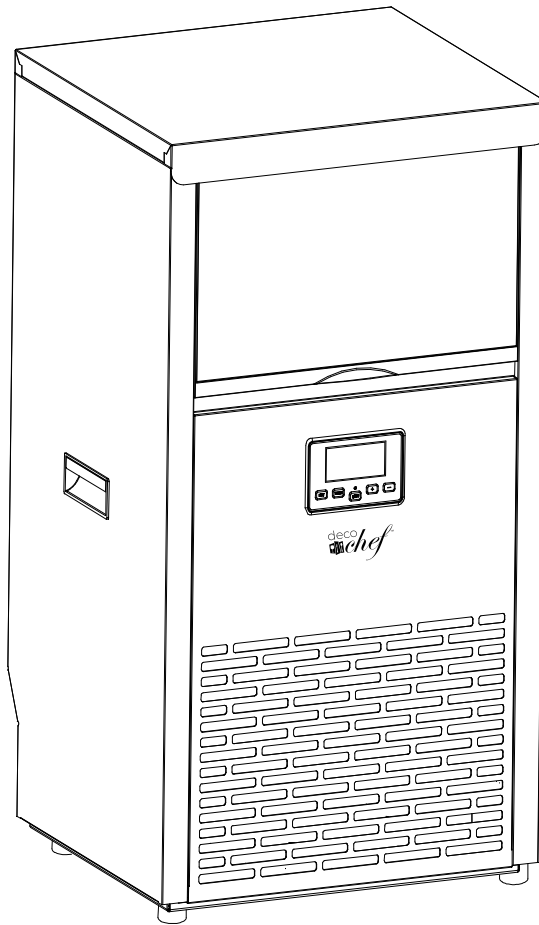

Automatic Ice Maker

Automatic water supply



Instruction Manual

To ensure proper use of this appliance and your safety, please read the following instructions carefully before operating this appliance.

[View this product on decogear.com](http://decogear.com)

CONTENTS

IMPORTANT SAFETY INSTRUCTION-----	2
IMPORTANT SAFTY TIPS-----	3
SPECIFICATION-----	5
DIMENSION/CONNECTION-----	5
RATING-----	5
GENERAL INFORMATION-----	6
MAIN UNIT CONSTRUCTION-----	6
ICE-MAKING AND ITS WATER TANK PARTS-----	6
OPERATION PANEL-----	7
EXPLOSIVE DRAWING-----	8
OPERATING PROCEDURE AND MAINTENANCE-----	10
UNPACKING YOUR ICE MAKER-----	10
INSTALLATION LOCATION REQUIREMENT-----	10
ELECTRICAL REQUIREMENT & CONNECTIONS-----	11
CLEANING YOUR ICE MAKER BEFROE FIRST USING-----	12
OPERATION YOUR UNIT-----	12
WATER CONNECTION FOR YOUR ICE MAKER-----	13
OPERATION THE ICE MAKING PROCESS-----	14
AUTOMATIC SELF-CLEANING PROGRAM-----	15
TIMER SETTING OPERATION-----	16
INTERNAL LED LIGHT OPERATION-----	16
ERROR CODE OF UNIT BREAKDOWN-----	16
WATER DRAINAGE-----	17
NORMAL SOUNDS-----	17
PREPARING ICE MAKER FOR LONG STORAGE-----	18
CLEAN AND MAINENANCE -----	18
EXTERIOR CLEANING-----	19
INTERIOR CLEANING-----	19
ICE MAKING PARTS CLEANING-----	19
ICE MAKING ASSEMBLY SYSTEM CLEANING BY USING NU-CALGON NICKLE SAFE ICE-MACHINE CLEANER -----	20
CLEANING SUGGESTION-----	21
WIRING DIAGRAM-----	22
NORMAL TROUBLE SHOOTING-----	23
WARRANTY-----	24

IMPORTANT SAFETY INSTRUCTIONS

Your safety and the safety of others are very important.

We have provided many important safety messages manual and your appliance.
Always read and obey all safety messages.

This is the safety alert symbol:



All safety messages will follow the safety alert symbol and the word “DANGER” or “WARNING”.



DANGER



WARNING

These words mean:

You can be killed or seriously injured if you don't immediate follow instructions.

All safety messages will tell you what the potential hazard is, tell you how to reduce the chance of injury, and tell you what can happen if the instructions are not followed.

IMPORTANT SAFETY TIPS

When using electrical appliances, basic safety precautions should be followed to reduce the risk of fire, electric shock, and injury to persons or property. Read all instructions before using any appliance.

Use this appliance only for its intended purpose as described in this owner's manual.

This ice-maker must be properly installed in accordance with the installation instructions before it is used.

This unit must be positioned so that the plug is accessible. Do not run cord over carpeting or other heat insulators. Do not cover the cord. Keep cord away from traffic areas, and do not submerge in water. No other appliance should be plugged into the same outlet, and be sure that the plug is fully inserted into the receptacle.

We do not recommend the use of extension cord as it may overheat and cause a risk of fire. If you must use an extension cord, use 16AWG minimum size and rated no less than 1875 watts.

If the supply cord is damaged, it must be replaced by the manufacturer or its service agent or a similarly qualified person in order to avoid a hazard.

Disconnect the mains plug from the supply socket when not in use for a long term, where supply connection is via mains plug.

Remove power plug or disconnect from the mains before cleaning or servicing the appliance. **NOTE:** *If for any reason this product requires service, we strongly recommend that a certified technician perform the service.*

Never unplug you unit by pulling on the power cord. Always grasp the plug firmly and pull straight out from the outlet.

Do not use your unit outdoors. Keep the unit away from direct sunlight and make sure that there is at least 6 inches of space between the back of your unit and wall and keep the front free. Keep ventilation opening in the appliance enclosure or in the built-in structure, clear of obstruction.

Do not tip over the unit, which will cause abnormal noisy and make the ice-cube size abnormal. And seriously, it may cause water leakage from the unit.

If the unit is brought in from outside in the winter season, give it a few hours to warm up to room temperature before plugging it in.

Do not use other liquid to make the ice-cube other than water.

Do not clean your ice maker with flammable fluids. The fumes can create a fire hazard or explosion.

● **WARNING:** This appliance must be earthed. Use the proper power source according to the

nameplate.

- **WARNING:** Keep ventilation openings, in the appliance enclosure or in the built-in structure, clear of obstruction.
- **WARNING:** Do not damage the refrigerant circuit.
- **WARNING:** This appliance is not intended for use by persons (including children) with reduced physical, sensory or mental capabilities, or lack of experience and knowledge, unless they have been given supervision or instruction concerning use of the appliance by a person responsible for their safety.
- **WARNING:** Children should be supervised to ensure that they do not play with the appliance.
- **WARNING:** This appliance must be earthed. And use the 110-120V/60Hz earthed power supply.
- **WARNING:** Do not store explosive substances such as aerosol cans with a flammable propellant in this appliance.
- **DANGER – Risk Of Fire or Explosion. Flammable Refrigerant Used. Do Not Use Mechanical Devices To Defrost Ice Maker. Do Not Puncture Refrigerant Tubing.**



- **DANGER – Risk Of Fire Or Explosion. Flammable Refrigerant Used. To Be Repaired Only By Trained Service Personnel. Do Not Puncture Refrigerant Tubing.**
- **CAUTION – Risk Of Fire Or Explosion. Flammable Refrigerant Used. Consult Repair Manual/Owner’s Guide Before Attempting To Install or Service This Product. All Safety Precautions Must be Followed.**
- **CAUTION – Risk Of Fire Or Explosion. Dispose Of Property In Accordance With Federal Or Local Regulations. Flammable Refrigerant Used .**
- **CAUTION-Risk Of Fire Or Explosion Due To Puncture Of Refrigerant Tubing;Follow Handling Instructions Carefully. Flammable Refrigerant Used.**
- The ice maker should be installed in accordance with the safety standard for Refrigeration Systems, ASHRAE15. The ice maker shall not be installed in corridors or hallways of public buildings.
- If the unit is with problem need to be maintained, that replacing with like components and that servicing shall be done by factory authorized service personnel, so as to minimize the risk of possible ignition due to incorrect parts or improper service.
- **WARNING:** This appliance is intended to be used in household and similar applications such as
Eg.staff kitchen areas in shops, offices and other working environments;
Eg. farm houses and by clients in hotels, motels and other residential type environments;
Eg.bed and breakfast type environments;
Eg.catering and similar non-retail applications.

IMPORTANT:

The wires in this mains lead are colored in accordance with the following code:

Green with or without yellow strip:	Grounding
White:	Neutral
Black:	Live

To avoid a hazard due to instability of the appliance, it must be placed at an even or flat surface.

SPECIFICATIONS

1) DIMENSIONS/CONNECTIONS

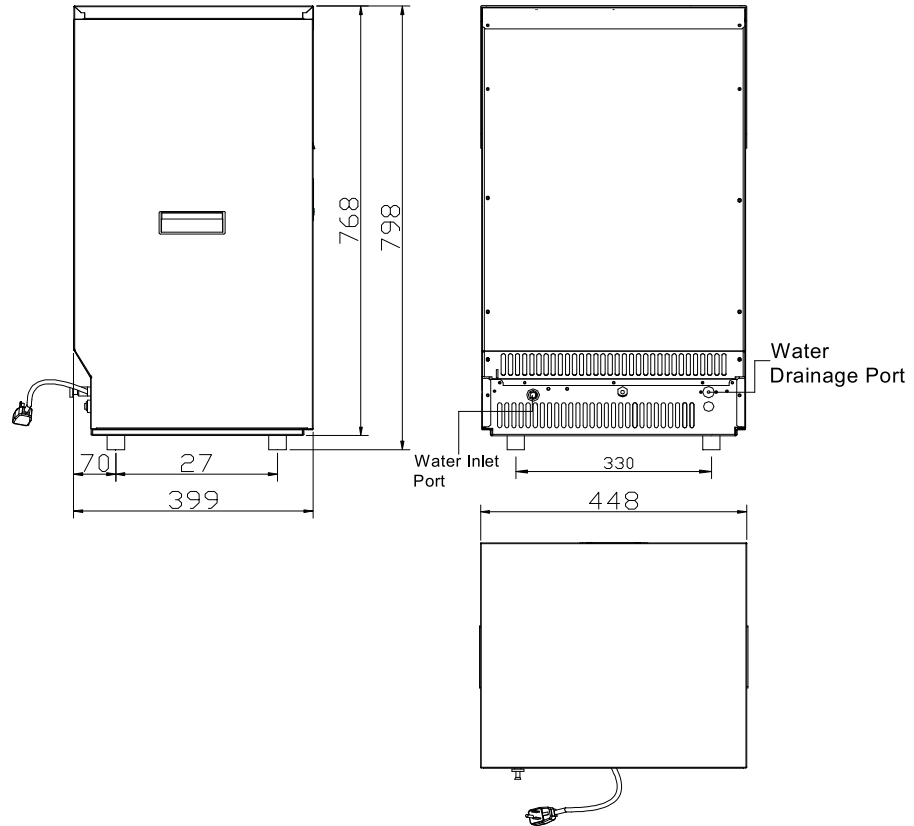

2) Rating

MODEL	DCCIMMSLV
POWER SUPPLY VOLTAGE	1Phase, 110-120/60Hz
CLAIMATE CLASS	10-40°C
ELECTRICAL PROTECTION CLASS	I
ICE MAKING RATING (Amps)	2.2Amp
ICE HARVEST RATING (Amps)	2.5Amp
ICE MAKING CAPACITY (KG/24H)	45kg/24Hour *
REFRIGERANT CHARGE	R290 3.35Oz / 95g
NET WEIGHT(lbs)	60.5 lbs
VESICANT	C ₅ H ₁₀
CONNECTION	POWER CORD---- 18 AWG WATER SUPPLY----6.35mm diameter DRAIN PIPE---- Φ 16mm SYLPHON BELLOWSS
MAX ICE STORAGE CAPACITY(lbs)	33lbs
ACCESSORIES	ICE SCOOP, INSTALLATION KITS
RUNNING CONDITIONS	ROOM TEMP 50-110 Fahrenheit WATER SUPPLY TEMP 41-95 Fahrenheit WATER SUPPLY PRESSURE 0.04-0.6 MPa

NOTE *: TESTED AT 70 Fahrenheit ROOM TEMPERATURE AND 50 Fahrenheit WATER TEMPERATURE.

GENERAL INFORMATION

1) Main Unit Construction

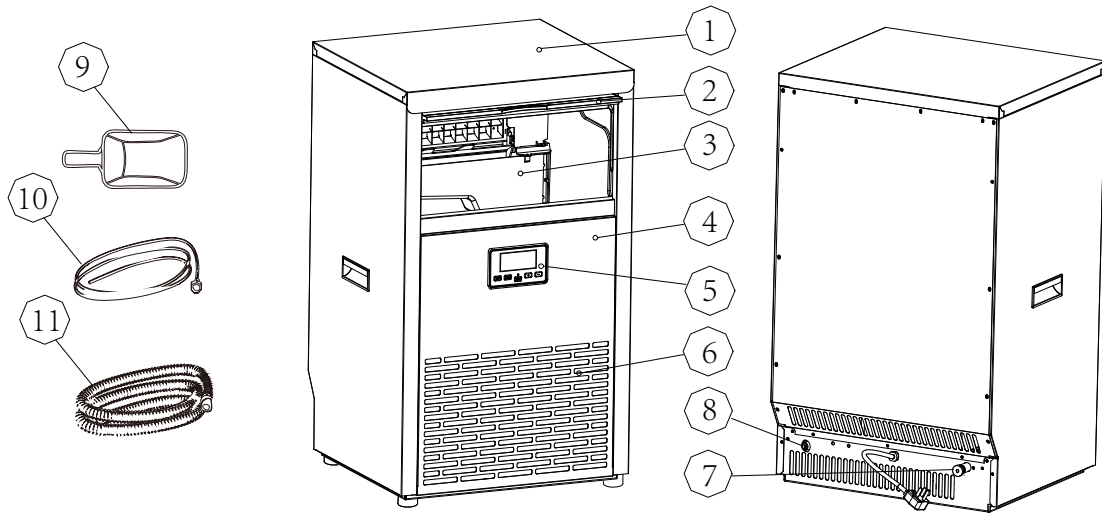

1. Top cover
2. Door for ice taking
3. Ice-making & its water tank assembly: Including ice-making evaporator, water tank, water charging tank, water pump and some detecting parts
4. Front panel
5. Operation panel
6. Air outlet: Must keep the air circulate smoothly, hot air will blow out when unit running.
7. Water draining port: Normal plugged with the cap. When need to drain the water, unplug the cap. And connect the white drain pipe.
8. Water inlet port for water supply: Use to connect the water supply pipe.

Accessory: 2 meters long and white color water drain pipe、
water quick connector of the water faucet,
ø6.35mm diameter and white color water supply pipe(3 meters long) 。

9. Ice Scoop
10. Water Hose
11. Drain House

3) Ice-making and its water tank parts

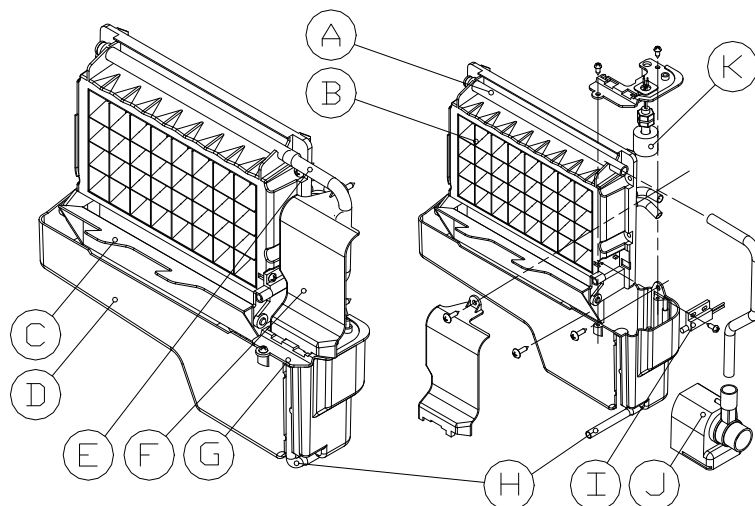

- A. Water dividing pipe : With eight little holes, water will flow out from these little holes. And if no water flows out, can be disassembled and cleaned.
- B. Evaporator (ice-making module)
- C. Ice full detecting board: Use to detect the inner cabinet is full of ice or not, and to check the ice-harvest process is over or not.
- D. Water tank for water circulation: Approximate 0.9 liters volume
- E. Water supplying pipe
- F. Cover board on the right side of the evaporator
- G. Water level switch installing plate
- H. Water drain pipe of the water tank : When ice-making, this pipe should be clamped in the slot of the water tank wall; And when draining, this pipe should be pulled out.
- I. Ice full detector
- J. Water circulation pump
- K. Water level detecting switch

4) Operation panel

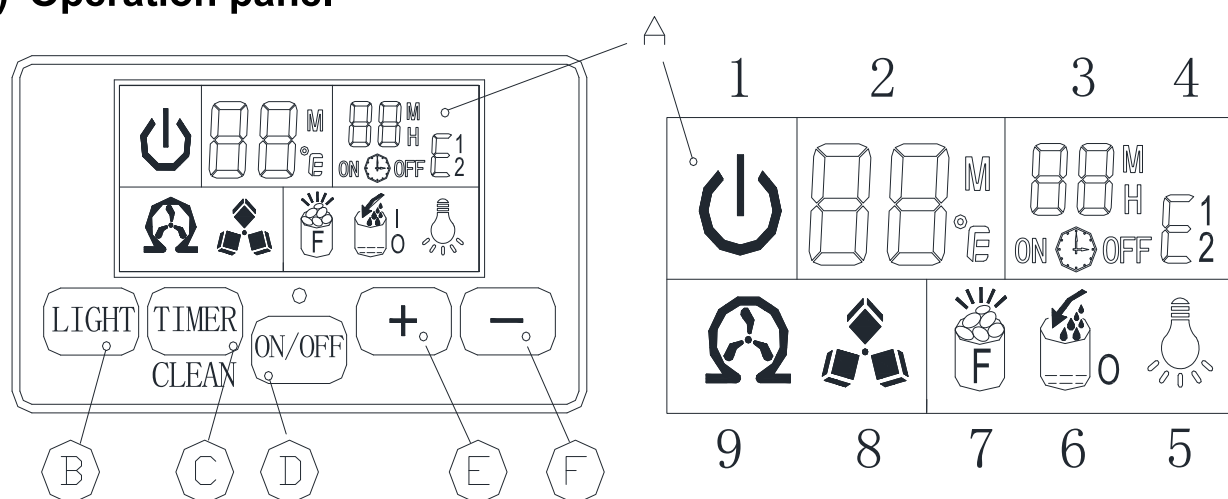

A. LCD display window

- 1、 Unit ON or OFF state symbol: When the unit is turned off(standby mode), this symbol flashes, and when the unit is working, the symbol will keep lighting on.
- 2、 Ambient temperature and ice-making countdown time display
- 3、 Ice-making setting and Timer setting display
- 4、 Error code: E1 means that the ambient temperature sensor is faulted
E2 means that ice-making process is abnormal;
- 5、 Light symbol: When this symbol displays, the LED light inside the cabinet will be on;
- 6、 Water flowing and water absence symbol: If the arrow of this symbol flashes, means the water is flow in from main water supply; And if the whole symbol keeps on, means there is no water from main water supply.
- 7、 Ice-full display: When the ice storing cabinet is full of the ice cube, this symbol will display, and the unit will stop ice-making process.
- 8、 Ice making and harvest display: When the ice cube symbol keep rotation, means the unit is making the ice; And if the symbol flashes, means the unit is during the ice harvest process.
- 9、 Self-cleaning display.

B. "LED light" button: To turn on or turn off the internal LED light;

Note: Keep pressing this button for more than 5 seconds, it is to change the ambient temperature unit between Fahrenheit degree and Centigrade degree.

C. "Timer/Clean" button: Quickly press this button once, to enter the Timer setting program; And press this button for more than 5 seconds, to let the unit enter the Self-Cleaning program.

D. "ON/OFF" button:

When the unit is off, press this button to turn on the unit; And during the automatic-cleaning program, or normal ice-making state, press this button to turn off the unit at once; And also if the unit is set with the Timer, press this button to cancel the Timer setting.

When the unit is making the ice cube, press this button for more than 5 seconds, the unit will switch to ice harvest process by force.

E/F. "+"、"-" button:

Use to adjust the ice-making process duration period length, the default setting is zero, 1 minute adding or decreasing per each pressing of "+" or "-" button.

Also to adjust the delay time of the timer, the default setting is zero, 1 hour adding or decreasing per each pressing of "+" or "-" button.

5) EXPLOSIVE DRAWINGS

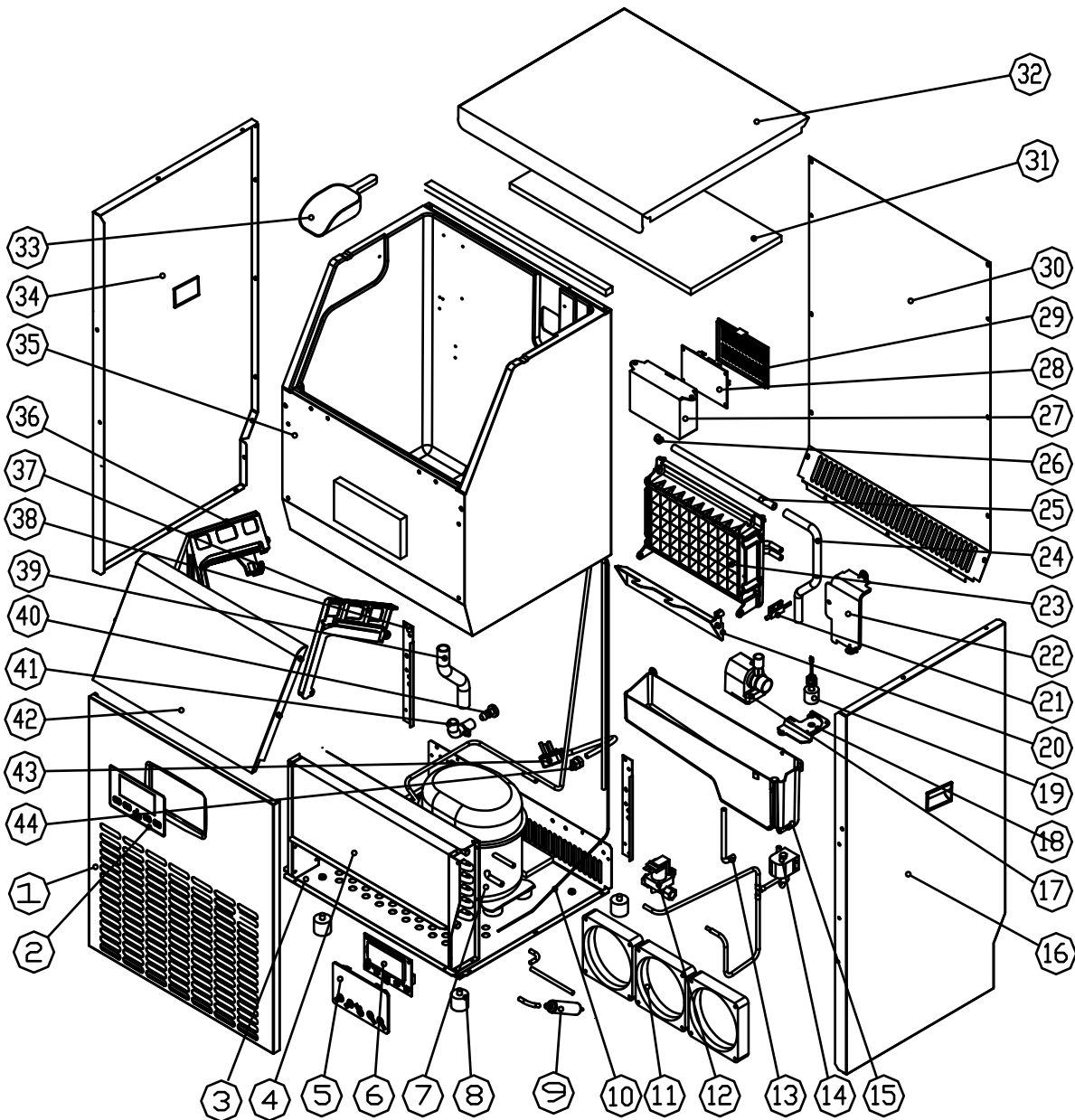

No.	Parts Name	Material	Qty.
1	Front panel	Stainless steel	1
2	Operation panel paper	PET	1
3	Bottom plate	Zinc-plated steel board	1
4	Condenser	Copper tube and aluminum fin	1
5	Operation panel PCB box	ABS	1
6	Operation panel PCB	Electrical and Electronic parts	1
7	Compressor	AC110-120V, 60Hz	1
8	Adjustable foot	ABS and bolts	4
9	Dry filter	Copper	1
10	Capillary	Copper	1
11	DC fan	DC12V, Electrical parts	3
12	Water inlet valve	DC12V Electrical parts	1
13	Water drainage pipe of the water tank	Silicone pipe	1
14	Ice-harvesting Electro-magnetic valve	AC115V/60Hz, Electrical parts	1
15	Water tank	ABS	1
16	Right side plate	430 stainless steel, 可选	1
17	Water circulation pump	AC110-120V,60Hz, Electrical parts	1
18	Cover of the water tank	ABS	1
19	Water level detecting switch	DC5V, Electrical parts	1
20	Ice-full detecting plate	ABS	1
21	Magnetic control switch	DC5V, Electrical parts	4
22	Cover board on the right side of the evaporator	ABS	1
23	Evaporator and its frame	Copper plated with nickle, and ABS frame	1
24	Water supplying pipe	Silicone pipe	1
25	Water dividing pipe, with nine holes	ABS	1
26	Cap of the water dividing pipe	Silicone	1
27	Electrical PCB box	ABS, fire-retardant	1
28	Main control PCB	PCB, Electrical parts	1
29	Cover of the main control PCB	ABS, fire-retardant	1
30	Rear plate	Zinc-pated steel	1
31	Insulation sponge of the top cover	PE	1
32	Top cover	Stainless steel	1
33	Ice shovel	ABS	1
34	Left side plate	430 Stainless steel, (Option)	1
35	Foaming inner cabinet & Ice storing bin	HIPS and Cyclopentane foaming	1
36	Left guideway	ABS	1
37	Right guideway	ABS	1
38	Back strength plate	Zinc-plated steel	1
39	Water outlet pipe of the inner cabinet	Silicone pipe	1
40	Water drainage cap	Rubber	1
41	Water drainage port	ABS	1

42	Door for ice taking	ABS	2
43	Power cord	Electrical parts	1
44	Clipper of the power cord	PP, fire-retardant	1
45	Wiring	Electrical parts	1

UNPACKING YOUR ICE MAKER

OPERATING PROCEDURES & MAINTENANCE

1. Remove the exterior and interior packaging. Check if all the accessories, including instruction manual, ice scoop, white water supplying pipe, 1/4 to 1/2 inches water quick connector and the water draining pipe, etc., are inside or not. If any parts are missing, please contact our customer service.
2. Remove the tapes for fixing the door and inner cabinet, ice scoop, etc.. Roughly clean the inner cabinet & ice scoop with wet clothe.
3. Put the ice maker on a level & flat floor, without direct sunlight and other sources of heat (i.e.: stove, furnace, radiator). Make sure that there is at least 8 inches gap between the air outlet and the obstacles, and at least 2 inches between Left/Right side and the wall.
4. Allow 4 hours for the refrigerant fluid to settle before plugging the ice maker in if the unit maybe fall upside down during shipping or transportation.
5. The appliance must be positioned so that the plug is accessible.

WARNING: Connect to the potable water supply only. Only use drinking water.

INSTALLATION LOCATION REQUIREMENT

- a) This unit is not for outdoor use. Keep the proper room temperature and inlet water temperature according to above specification table. Otherwise it will affect the ice making performance.
- b) This unit should not be located near any heat resource.
- c) The unit should be located on a firm & level foundation at normal counter top height.
- d) There must be at least 6 inches clearance at rear side for connection and 8 inches clearance in front to open the door and keep good air circulation.
- e) Do not put anything on the top of the ice maker.

Installation clearance
top view (mm)

Side view (mm)

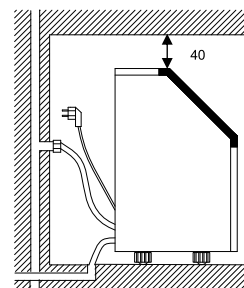
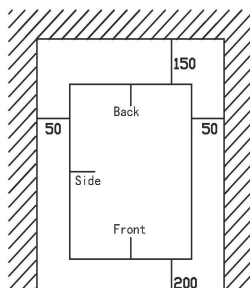

To ensure proper ventilation for your ice maker, the front of the unit must be completely unobstructed (at least 20CM free space). Allow at least 6 inches clearance at rear, and 2 inches sides for proper air

circulation. And allow 2 inches at top and sides for proper air circulation. The installation should allow the ice maker to be pulled forward for servicing if necessary.

When installing the ice maker under a counter, follow the recommended spacing dimensions shown above. Place electrical and drain fixtures in the recommended locations as shown.

Choose a well-ventilated area with temperatures above 50 Fahrenheit and below 90 Fahrenheit. This unit MUST be installed in an area protected from some elements, such as wind, rain, water spray or drips.

The ice maker requires a continuous water supply with pressure 1-8 Bar as required in above specification table. The temperature of the water feeding into the ice maker should be between 41 Fahrenheit and 77 Fahrenheit for proper operation.

ELECTRICAL REQUIREMENT & CONNECTIONS

WARNING: THIS UNIT MUST BE EARTHED.

Electrical Shock Hazard

Plug into a grounding wall outlet.

Never remove the ground prong.

Use separate power supply or receptacle.

Never use an adapter.

Never use an extension cord.

Failure to follow these instructions can result in death, fire, or electrical shock.

Before you move your ice maker into its final location, it is important to make sure you have the proper electrical connection.

It is recommended that a separate circuit, serving only your ice maker, be provided. Use receptacles that cannot be turned off by a switch or pull chain. If the supply cord or plug to be replaced, it should be done by a qualified service engineer.

This appliance requires a standard 110-120Volt, 60Hz electrical outlet with good grounding means.

Recommended grounding method

For your personal safety, this appliance must be properly grounded. This appliance is equipped with a power supply cord having a grounding plug. To minimize possible shock hazard, the cord must be plugged into a mating grounding-type wall receptacle, grounded in accordance with the National Electrical Code and local codes and ordinances. If a mating wall receptacle is not available, it is the personal responsibility of the customer to have a properly grounding wall receptacle installed by a qualified electrician.

CLEANING YOUR ICE MAKER BEFORE FIRST USING

Before using your ice maker, it is strongly recommended to clean it thoroughly.

1. Open the ice taking door.
2. Clean with diluted detergent, warm water and a soft cloth.
3. Repeatedly clean the water contacting inner parts, use the water or the wet clothe to scrub the relevant parts, then use the dry clothe to dry them.
4. You can pull the Water drain pipe of the water tank indicating "H" in above illustration to drain out the cleaned water in the water tank, then next to clean inner ice-storing bin, till all of inner parts are cleanly, then drain out all of the cleaned water from the water drain port located at unit back indicating "8" in above illustration. And must to install back the water drain pipe of the water tank and the cap of the unit water drain port, otherwise, the unit will not make the ice normally. **And suggest that you should discard the ice-cube made by the first ice making cycle after cleaning. Note: Please see the section "Water Drainage" in this manual to drain out the cleaned water.**
5. The outside of the ice maker should be cleaned regularly with a mild detergent solution and warm water.
6. Dry the interior and exterior with a clean soft cloth.

OPERATION YOUR UNIT

WATER CONNECTION FOR YOUR ICE MAKER

Important: Be sure to use the new hose-sets supplied with the appliance to connect to water mains and that old hose-sets should not be reused.

1. Connect the water supplying hose to the unit

Step 1: First remove the clipper on the water inlet port for main water supplying (indicated in the following illustration "B") located at unit back, then pushing inwards the anti-dusty plug, use your other hand's finger to press the out circle to fix the anti-dusty plug, then take down the anti-dusty plug;
Step 2: Insert the one end of the white water supplying hose into the water inlet port, and push inward completely, and install back the clipper, then water supplying hose connection is completed.

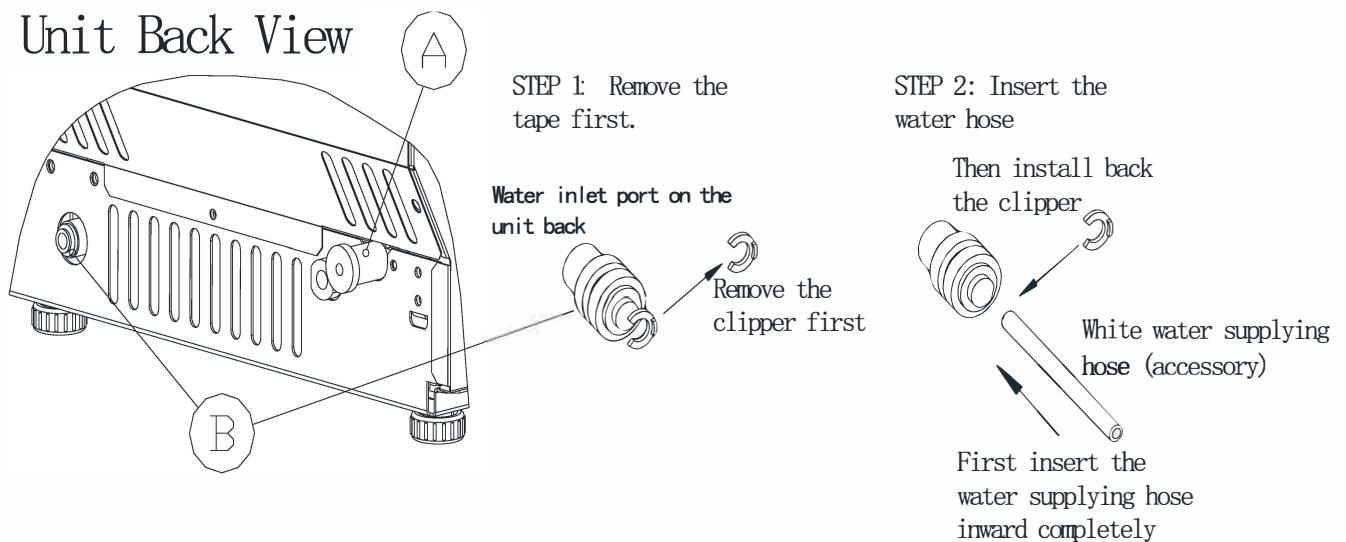

2. Connecting the water drainage pipe

Pull out the water drainage cap with black color (indicated **A** in above illustration), then

connect the white drainage pipe included in accessory, again connect the other end of this drainage to the main water drainage pipeline. Make sure not to set the drainage pipe too high.

3. Connect the water hose to the water faucet of the water main supply system

First, install the supplied water quick-connector(from 1/4 to 1/2 inch, with black sealing circle) to the water faucet by screw thread; Second, remove the clipper from the water quick-connector, insert the another end of the water hose into this quick-connector port completely, then install back the clipper, also this step is completed. Note: The water faucet should be supplied by the customer himself.

Important: The water pressure of main water supply system must be 0.04-0.05 MPa at least and 0.6 Mpa at largest. If the pressure is too big, it should be installed with pressure decreasing valve first.

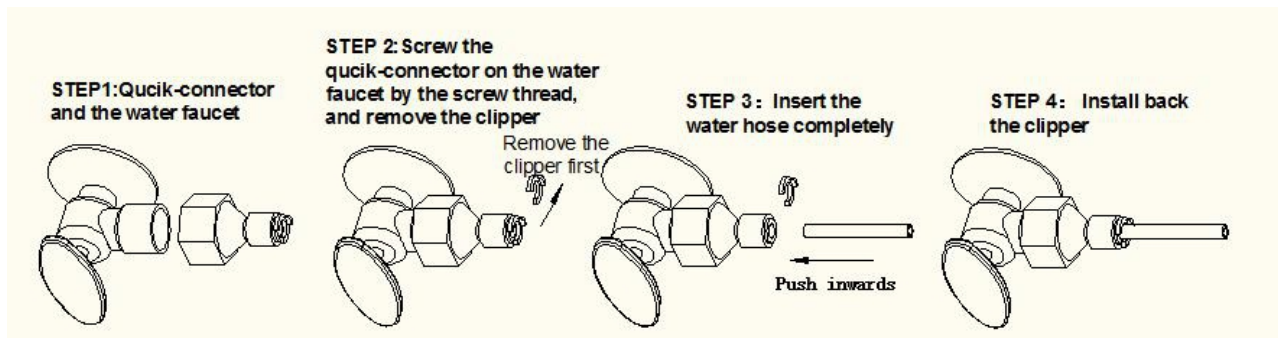

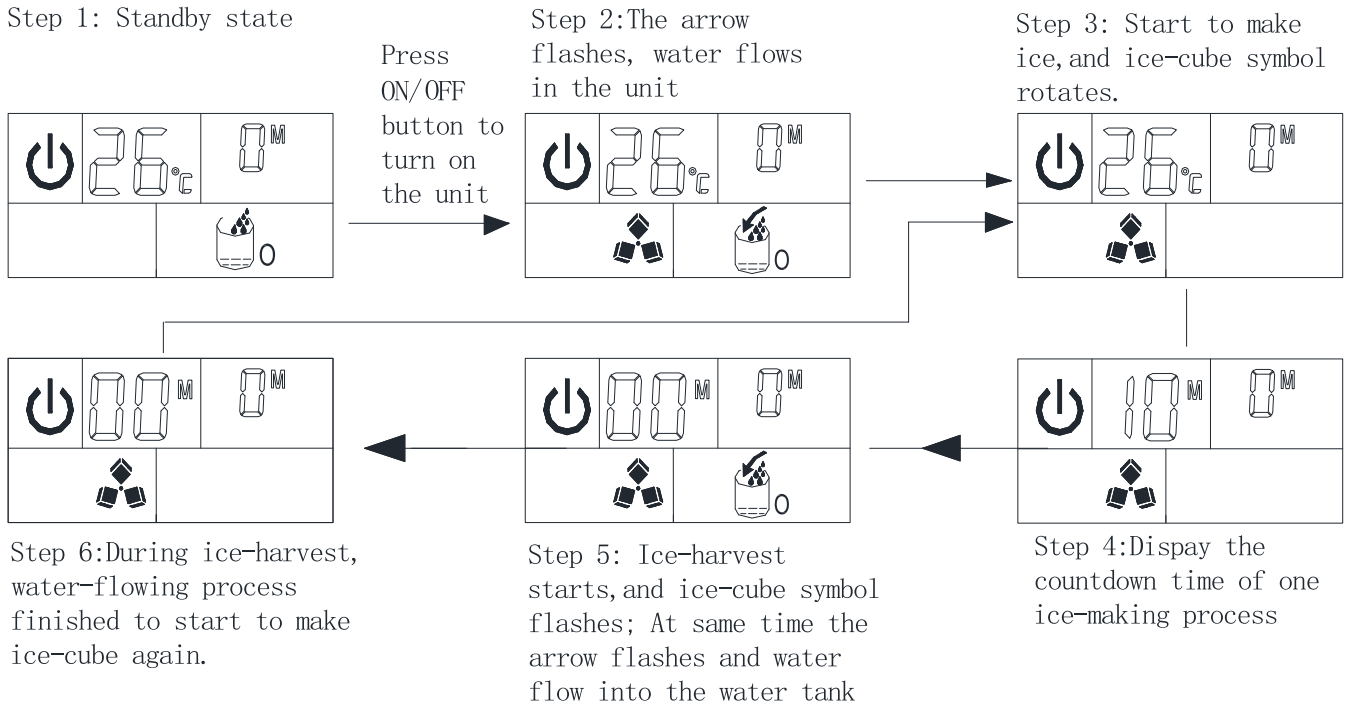

OPERATION THE ICE-MAKING PROCESS

Ice making program is explained in following chart:



 Automatic water supplying symbol

 Arrow of symbol flashes, means the water is flowing

into the water tank.  If this whole symbol keeps displaying, means no main water supplying at present.

 Ice-cube symbol, when it rotate, means unit is making the ice cube; and it flashes, means the unit is in ice harvest process.

F Fahrenheit(ambient temperature) **H** unit of hour (setting the timer) **M** unit of minute
(ice-making setting and countdown time)

1. After completing the connection of the main water supplying hose with the unit, plug on the main power supply plug. Then press "ON/OFF" button on the control panel to begin the ice making cycle. The unit ON/OFF state symbol will keep lighting on, the left number in the LCD display window displays the present ambient temperature, and the right number displays the present ice-making setting, and the ice-cube symbol rotates. When the left number change to flash, then the number means the countdown time to complete one ice making cycle.
2. Each ice making cycle will last about 11 to 20 minutes, depending on the ambient temperature and

the water temperature. And for the first time, according to the initial water temperature, ice-making last time will be a little longer.

3. When the ice-making process is over, then switch to ice-harvest process. During the ice-harvest process, the ICE cube symbol change rotating to flash. At same time, the arrow on the manual filling water symbol will start to flash, the water will flow into the water tank again till the floating ball of water level switch rises up to the highest position, then the water stop flowing and the whole manual filling water symbol will disappear.

When the ice-harvest finish, the Ice-full detecting plate will rotate downward once, then recover to the original position and enter to the next ice-making process.

If after the rotation of the Ice-full detecting plate, it is pressed by the ice cube and can't recover to the original position, means the the ice storage bin is full of the ice cube and it will stop making the ice automatically.

4. When the "ICE-FULL " symbol display is on, the unit stops running. And if you move away the ice cube, the unit will start to make the ice cube again. But it will restart only after 3 minutes interval of compressor running.
5. During the ice-making process, press the "+" or "-" button to adjust the ice-making process duration period length, then to change the thickness of the ice cube. Press the "+" or "-" button, the right digit will flash, the default setting is zero, 1 minute will add or decrease to each ice making process per each pressing of "+" or "-" button. After 5 second of setting, the new setting will be remembered by the system.
6. The bad water quality will cause the bad quality of ice cube, and reduce the transparency of the ice cube.

Automatic self-cleaning program

Start the self-cleaning program: After connecting all of the water pipe, plug on the main power supply plug, then press "TIMER /CLEAN" button on control panel for more than 5 seconds, to enter

the Self-Cleaning program. And the " " symbol will always be on during this period, the left digit will indicate the left time. The total duration time is 20 minutes for one self-cleaning program.



Cancel the self-cleaning program: It takes about 20 minutes to complete one self-cleaning program. When the program is over, the system will be in standby mode automatically. And also you can press the "ON/OFF" button on control panel to cancel the self-cleaning program by force.

Timer setting operation



Delay time range: 1-24 hours, Default time: 1 hour

How to set the ON-Timer: During the unit is in standby mode, press the "TIMER/CLEAN" button to set

the ON-Timer. The " " symbol will start to be on, the number "1" above the symbol will flash to display the set delay time. During the number flashing, press "+" 、 "-" button to change the delay time of the timer, 1 hour increasing or decreasing per each pressing of "+" or "-" button. Five seconds after setting, your desired setting will be remembered.

How to cancel the ON-Timer: Press the “TIMER/TIMER” button, the number above the “ON  ” symbol will flash to display the present delay time of your ON-Timer, and press this button once again to cancel the Timer setting, also the “ON  ” symbol and the number will disappear. And the second easy way to cancel the ON-Timer is to press the “ON/OFF” button, it will cancel the ON-TIMER setting by force.

How to set the OFF-Timer : When the unit is working, press the “TIMER/CLEAN” button to set the OFF-Timer. The “ OFF ” symbol will start to be on, the number “1” above the symbol will flash to display the setting delay time. During the number flashing, press+” 、 “-” button to change the delay time of the timer, 1 hour increasing or decreasing per each pressing of “+” or “-” button. Five seconds after setting, your desired setting will be remembered.

How to cancel the OFF-Timer: Press the “TIMER/TIMER” button, the number above the “ OFF ” symbol will flash to display the present delay time of your OFF-Timer, and press this button once again to cancel the Timer setting, also the “ OFF ” and the above number will disappear; And also the second easy way to cancel the OFF-Timer is to press the “ON/OFF” button, it will cancel the ON-TIMER setting by force, also will turn off the unit.

Internal LED light operation

When the unit is plugged on, press the “LIGHT” button on the operation panel once to lighten the LED light inside the ice bin and the “ ” symbol on the LCD display window will also be on.

Press this button once again, the LED light and the “ ” symbol will be off at same time.

NOTE: If you press the “LIGHT” button for more than 5 seconds, the ambient can be changed between Centigrade degree and Fahrenheit degree (between °C and °F)

ERROR code of unit breakdown

When the unit is breakdown, the error code will display in the left side of LCD display window.

E1 means the sensor of ambient temperature is malfunction.

E2 means that ice making program is abnormal, including too big ice-cube, no ice falling off, or not making ice cube, etc.

NOTE: During the ice cube making process, press “ON/OFF” button for more than 5 seconds, the unit will jump into the ice-harvest process. After the ice harvest process is completed, the unit will recover to ice making process.

Water Drainage

Make sure the water drainage pipe has correctly connected at the unit back first.

A. You can drain the water in ice bin through the white drainage pipe connected on the back drainage port. Make sure not to set the white drainage pipe too high.

B. For the water in the water tank, you can pull out the silicone pipe on the right side of the water tank indicating "H" (refer to page 7) in above illustration to drain out the cleaned water in the water tank till the silicone pipe extend completely, the water can flow out to ice bin. Then the water can be drained out through the the water drain port at unit back.

Reminding: Clean the water tank frequently, it can improve the ice-cube quality and the unit and its water circulation pump can work much longer.

Normal Sounds

Your new ice maker may make sounds that are not familiar to you. Most of the new sounds are normal. Hard surfaces like the floor, walls and cabinets can make the sounds seem louder than they actually are. The following describes the kinds of sounds that might be new to you and what may be making them.

- You will hear a swooshing sound when the control valve opens to let water flow into the water tank for each ice-making cycle.
- Rattling noises may come from the flow of the refrigerant or the water line. Items stored on top of the ice maker can also make noises.
- The high-efficiency compressor may make a pulsating or high-pitched sound.
- Water running from the water tank to the evaporator plate may make a splashing sound.
- Water running from the evaporator to the water tank may make a splashing sound.
- As each cycle ends, you may hear a gurgling sound due to the refrigerant flowing in your ice maker.
- You may hear air being forced over the condenser by the condenser fan. During the harvest cycle, you may hear the sound of ice cubes falling into the ice storage bin.
- When you first start the ice maker, you may hear water running continuously. The ice maker is programmed to run a rinse cycle before it begins to make ice.

Preparing the Ice Maker for Long Storage

If the ice maker will not be used for a long time, or is to be moved to another place, it will be necessary to drain out all of the water in the system.

1. Allow all of the ice cubes have been ejected from the evaporator of ice maker.
2. Turn off the unit, and unplug the power cord.
3. Drain out all of the water inside the unit according to section "**Water Drainage**". When all of the water has been drained out, to install back the water drain pipe of the water tank..
4. Disconnect the water drainage pipe to the main drain pipeline or floor drain, plug on the drain cap again.
5. Drop the door open to allow for circulation and prevent from molding and mildewing.
6. Leave the power cord disconnected until ready to reuse.
7. Dry the interior & wipe the outside of the unit.
8. Put a plastic bag on the unit to resist out dust & dirty.

CLEANING & MAINTENANCE

WARNING: Before carrying out any cleaning or maintenance operations, unplug the ice maker from the main power supply electricity. (EXCEPTION: Ice maker self-cleaning program).

Do not use any alcohol or fume for cleaning or sanitization of the ice maker. It may cause cracks on the plastic parts.

Ask a trained service person to check and clean the condenser at least once a year, in order to let the unit work properly.

This appliance must be cleaned by use of a water jet.

CAUTION

If the ice maker has been left unused for a long time, before the next use it must be thoroughly cleaned. Follow carefully any instructions provided for cleaning or use of sanitizing solution. Do not leave any solution inside the ice maker after cleaning.

Periodic cleaning and proper maintenance will ensure efficiency, top performance, hygienic, and long life. The maintenance intervals listed are based on normal conditions. You may want to shorten the intervals if you have pets, or the unit is used outdoors, or there are other special considerations.

What shouldn't be done

Never keep anything in the ice storage bin that is not ice: objects like wine and beer bottles are not only unsanitary, but also it's labels may slip off and obstruct the drain pipe.

Exterior Cleaning

The door and cabinet may be cleaned with a mild detergent and warm water solution such as 28g of dish washing liquid mixed with 7.5L of warm water. Do not use solvent-based or abrasive cleaners. Use a soft sponge and rinse with clean water. Wipe with a soft clean towel to prevent water spotting.

The side steel plate can discolor when exposed to chlorine gas and should be cleaned. Clean the steel plate with a mild detergent and warm water solution and a damp cloth. Never use abrasive cleaning agents.

Interior Cleaning

For Ice Storage Bin

The ice storage bin should be sanitized occasionally. Clean the bin before the ice maker is used for the first time and reused after stopping for an extended period of time. It is usually convenient to sanitize the bin after the ice making system has been cleaned, and the storage bin is empty.

1. Disconnect power to the unit.
2. Open the door and with a clean cloth, wipe down the interior with a sanitizing solution made of 28g of household bleach or chlorine and 7.5L of hot water (95 F to 115 F).
3. Rinse thoroughly with clear water. The waste water will be drained out through the drain pipe.
4. Reconnect power to the unit.

The ice scoop should be washed regularly. Wash it just like any other food container.



WARNING

DO NOT use solvent cleaning agents or abrasives on the interior, These cleaners may transmit taste to the ice cubes, or damage or discolor the interior.

Ice Making Parts Cleaning

During the using, periodically to clean these main system of your ice-maker.

1.Repeat above step to clean the water tank and other inner parts of the unit.

2.Especially, to the water dividing pipe on the evaporator, when the compressor and the water pump run normally, but if there is no water flowing out from the water dividing pipe or the water flowing is very small, please discharge this water dividing pipe to clean carefully. Clean each little holes on the water dividing pipe displayed in the following illustration, make sure each hole is not clogged by something, then install back to the original location.

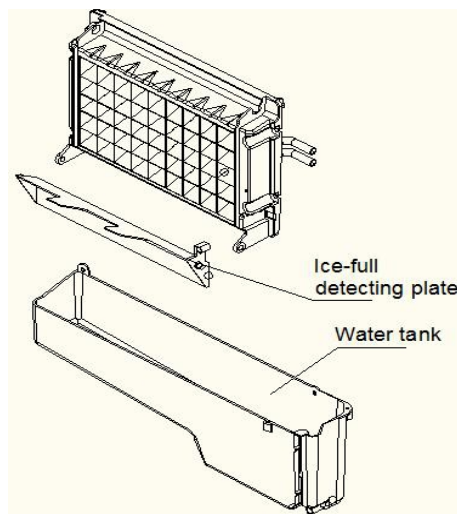

3.The length of cleaning period is related to your water quality. And drain the water more frequently, the unit and its water pump can work much longer.

4.When there are ice cubes on the surface of the evaporator, but can't fall off easily, do not use the mechanical substance to remove it by force; Only press the "ON/FF" button for more than 5 seconds, the unit will enter the ice melting process, after some while, the big ice-cubes will fall down, then turn off the unit and unplug the power cord to clean the surface of the evaporator.

5.For the water tank and ice-full detecting plate

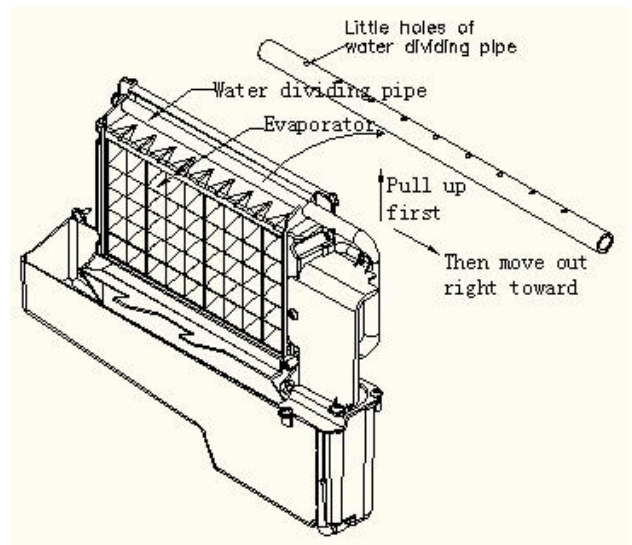

Also the water tank and the ice-full detecting plate is very important to keep your ice cube hygienic. Put mixture of neutral cleaner & water into a clean water jet, then spray to all the inner surface of tank & the ice detecting plate. Wipe these surfaces as far as possible with a clean cloth. And then, spray the surfaces with clean water, wiping with a dry clean cloth. Then drain out the cleaned water in the water tank by pulling out the Water drain pipe of the water tank indicating "H" in above illustration. When all of the cleaned water has been drained out, to install back the water drain pipe of the water tank.

Suggestion: After cleaning the interior parts and install back to its respective position, and return machine to work, discard first batch of ice.

Ice Making Assembly System Cleaning by Using Nu-Calgon Nickle Safe Ice-machine Cleaner

Minerals that are removed from water during the freezing cycle will eventually form a hard scaly deposit in the water system. Cleaning the system regularly helps remove the mineral scale buildup. How often you need to clean the system depends upon how hard your water is. With hard water of 4 to 5 grains/liter, you may need to clean the system as often as every 6 months.

1. Turn off the ice maker. Keep the ice maker connect to the water supply and drainpipe. But shut off the water faucet of main water supply.
2. Open the door and scoop out all of the ice cubes. Either discard them or save them in an ice chest or cooler.
3. Making the cleaning solution. Please mix the Nu-Calgon Nickle Safe Ice Machine Cleaner with water to make the cleaning solution.

! WARNING

Wear rubber gloves and safety goggles (and/or face shield) when handling Ice Machine Cleaner or sanitizer.

Use a plastic or stainless container with more than 4 liters capacity, mix 300 ml Nu-Calgon Nickle Safe Ice-machine Cleaner with 2.8 liters warm water about 120 F-140 F, . Then divide them for 2 shares equally in 2 cups. It is better to keep the temperature of each cup of the cleaning solution.

4. Check to be sure that the water drain pipe of the water tank has been installed properly in the slot of the tank wall. Then Pour one cup of Nickel-Safe Ice Maker Cleaning Solution into the water tank. Wait about for 5 minutes.

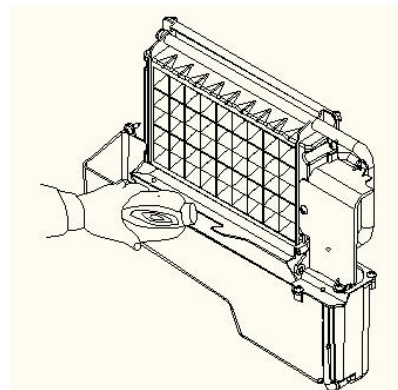

5. Turn on the power to the ice maker, then press “TIMER/ CLEAN” button on control panel for more than 5 seconds, to enter the self-Cleaning program. Same as above explanation, the water pump runs for 8 minutes and stops for 3 minutes, one cycle, again one cycle. The total duration time is 20 minutes for one self-cleaning program.

During this process, the “” symbol will always be on during this period, and the digit window will indicate the left time,

6. After 20 minutes of one self-cleaning program completing, pull out the drain pipe of the water tank, drain the cleaning solution down to the lower ice storage bin. Shake the unit slightly to drain out all of the cleaning solution completely. Then install back the drain pipe to the slot of the water tank.
7. Repeat steps 4--6 to clean the ice making assembly system again.

WARNING

The ice machine cleaner contains acids.
DO NOT use or mix with any other solvent-based cleaner products.
Use rubber gloves to protect hands. Carefully read the material safety instructions on the container of the ice machine cleaner.

8. Then open the water faucet of the main water supply, Let the water flow in the unit. And press the “TIMER/CLEAN” button on control panel for more than 5 seconds, to enter the self-Cleaning program.
9. Same as above explanation, the water pump runs for 8 minutes and stops for 3 minutes, one cycle, again one cycle. The total duration time is 20 minutes for one self-cleaning program.
During this process, the “” symbol will always be on during this period, and the digit window will indicate the left time. Through this process, It will rinse the water dividing pipe, evaporator, water pump, silicone pipe, and water tank, etc..
10. After one self-cleaning program complete, then pull out the drain pipe of the water tank, drain the cleaning solution down to the lower ice storage bin, also shake the unit slightly to drain out all of the water completely. Then install back the drain pipe to the water tank slot tightly.
11. Repeat the step 8-9 again for 2 times.
12. Following the above program to clean the ice storage bin .
13. Then this special cleaning program finish, you can return to the regular ice making mode. And suggest to discard the first batch of ice cube.

Cleaning Suggestion

1) DAILY CLEANING

The ice shovel, door and the water dividing pipe should be cleaned by yourself per each day. At the end of every day, rinse the ice shovel and wipe the both sides of the door with a clean cloth.

2) SEMI-MONTHLY CLEANING

The ice shovel, ice bin, water tank, the ice-full detecting plate and the surface of the evaporator are to be cleaned by yourself semi-monthly according to interior cleaning program.



3) SEMI-ANNUAL CLEANING

All the components & surfaces exposed to water or ice cubes, like ice storage bin, water tank, door, evaporator, water pump, silicone tube, water dividing pipe, etc. should be cleaned **by Using Nu-Calgon Nickle Safe Ice-machine Cleaner** per each 6 months. They should be cleaned by the serviceman according to ice making assembly system cleaning program.

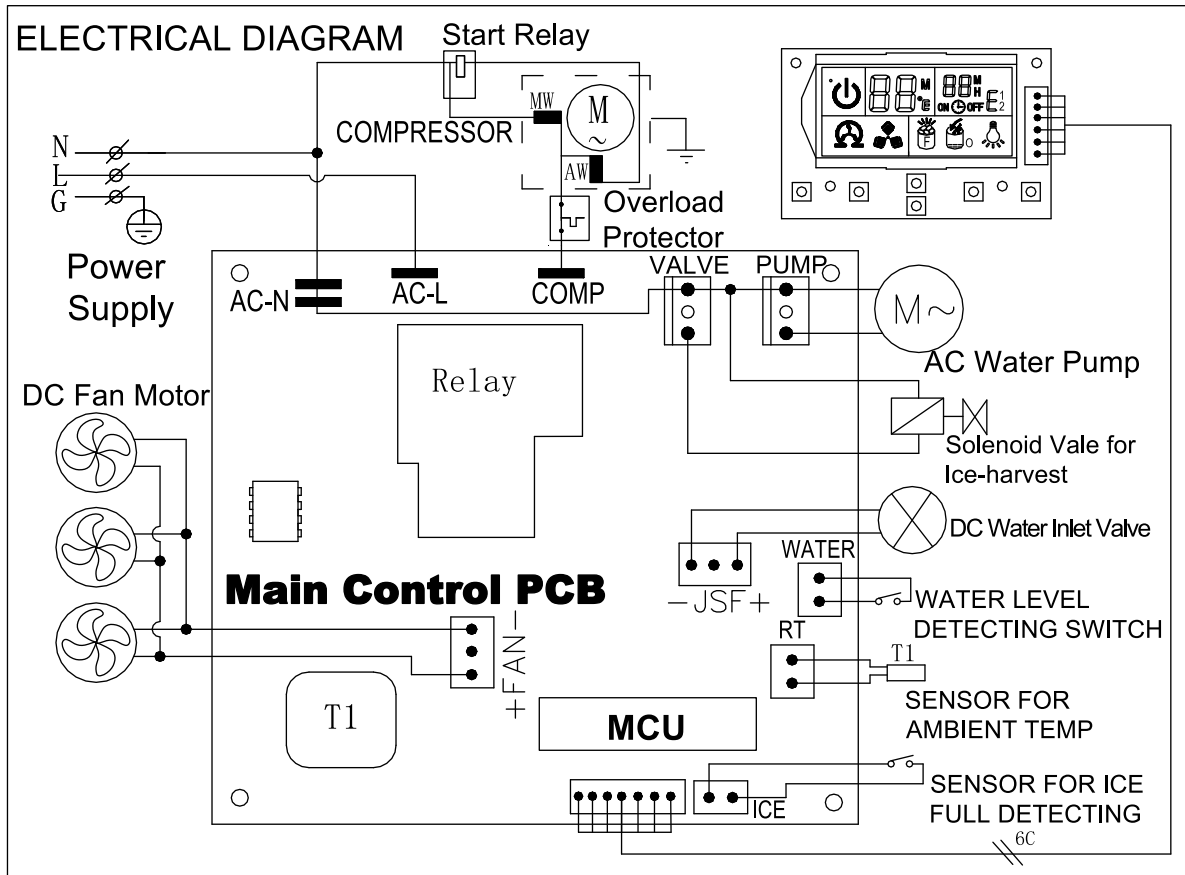
WIRING DIAGRAM



NORMAL TROUBLE SHOOTING

Problem	Possible Cause	Solution
The whole “” symbol is always on.	No water in unit	The main water pressure is too low or the water supplying hose is blocked. Check them and increasing the water pressure and clean the supplying hose
	Floating ball of the water level detecting switch is blocked, can't be raised up	Clean the water tank and the water level detecting switch
	Water flows out from the side of the water tank	Place the unit on the level position, not on the slope
	Water flows out from the water drain pipe of the water tank.	Pull out the pipe and install back to the right side slot of the water tank properly.
The unit enter the ice making process, but no water flowing in the unit, and the whole “” symbol is on.	No water in water tank, or the water supplying problem , or the silicone pipe of water tank isn't on the correct position.	The main water pressure is too low or the water supplying hose is blocked. Check them and increasing the water pressure and clean the supplying hose The silicone pipe of water tank should be clamped in the slot of the water tank side.
Water pump work, but no water flow out from the water dividing pipe	The little holes on the water dividing pipe is blocked.	Clean these little holes.
Water circulation pump doesn't work	Some special substance in water tank block the pump blade.	Clean the water tank and the water pump
The transparency of the ice cube is not very good	Water quality is bad	Use the water filter or water purifier to soften or filter the water.
Ice cube shape is irregular	Water quality is not good or the water tank is very dirty	Clean the water tank, and change with new water.
	The little holes on the water dividing pipe is some blocked	Clean the water dividing pipe, make sure all nine holes are unclogged
Ice cube is very thin	Ambient temperature is too high	Move the unit to low temperature space, or lengthen the time of each ice making cycle.
	Air circulation around the unit is not good	Make sure there is more than 8 inches space between the unit back & front and the obstacle
Ice cube is too thick	Ambient temperature is too low	Reduce the time of each ice making cycle.
“ICE-FULL” symbol is on	The ice storage bin is full of the ice cube.	Take out some ice cube
Ice making cycle is normal, but there is no ice cube produced	The temperature of ambient, or water in water tank is too high	Move to the place with temperature lower than 90 Fahrenheit, and change to the low temperature water
	Refrigerant leakage, E2 error code display	Need the technical serviceman to maintain
	Cooling system tube is clogged	Need the technical serviceman to maintain



Manufacturer's 1-Year Limited Warranty

The manufacturer warrants that all parts and components are defect free in materials and workmanship for 1 year. This warranty is valid only in accordance with the conditions set forth below:

1. The warranty extends only to the original consumer purchaser and is not transferable. In addition, proof of purchase must be demonstrated.
2. This limited warranty is the only written or express warranty given by the manufacturer. Any implied warranty of merchantability or fitness for a particular purpose on this product is limited in duration to the duration of this warranty. Some states do not allow limitations on how long an implied warranty lasts, so the above limitation may not apply to you.
3. This warranty gives you specific legal rights. You may also have other rights which vary by state

Procedure for Replacement or Return within the 1 Year:

To return the product for replacement or refund within the 1 year, the original purchaser must pack the product securely and send it postage paid with a description of the reason for replacement or refund, proof of purchase, and include your order number on the package, to the following address:

Deco Chef
80 Carter Drive
Edison, NJ 08817

