

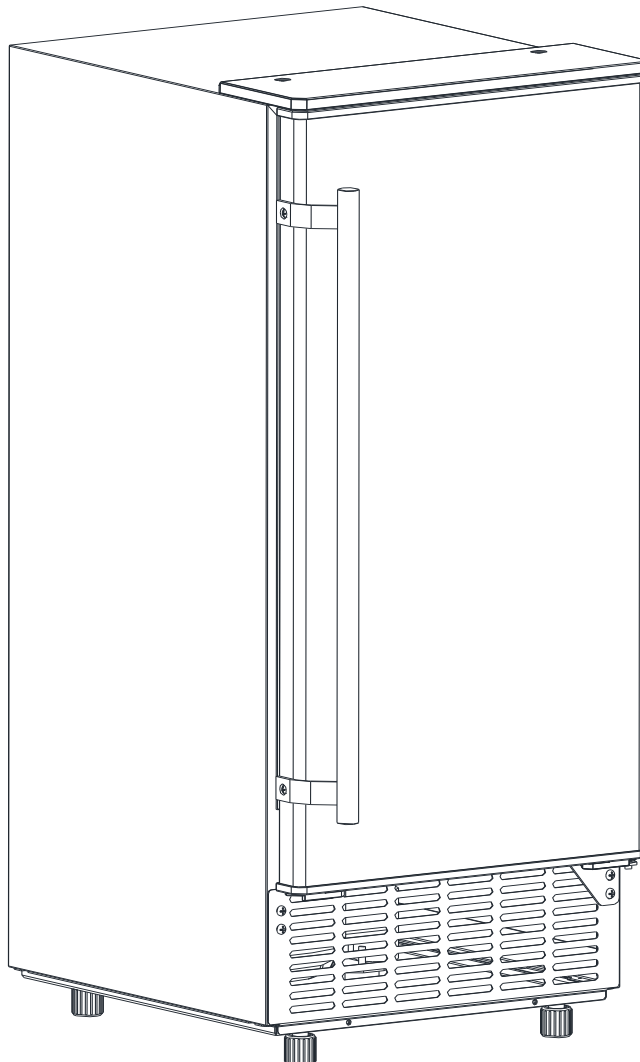

80LB Under Counter Automatic Ice Maker



Instruction Manual
Model: DGUTICM01

To ensure proper use of this appliance and your own safety, please read the following instructions carefully before operating.

CONTENTS

IMPORTANT SAFETY INFO	2
SPECIFICATION	4
DIMENSION/CONNECTION	4
RATING	4
GENERAL INFORMATION	5
MAIN UNIT CONSTRUCTION	5
ICE-MAKING AND ITS WATER TANK PARTS	5
OPERATION PANEL	6
EXPLOSIVE DRAWING	7
OPERATING PROCEDURE AND MAINTENANCE	9
UNPACKING YOUR ICE MAKER	9
DOOR REVERSING(Optional)	9
INSTALLATION LOCATION REQUIREMENT	11
ELECTRICAL REQUIREMENT & CONNECTIONS	12
CLEANING YOUR ICE MAKER BEFORE FIRST USING	12
WATER CONNECTIONS FOR YOUR ICE MAKER	13
OPERATION YOUR UNIT	14
OPERATION THE ICE MAKING PROCESS	14
WIRING DIAGRAM	16
NORMAL SOUNDS	16
PREPARING ICE MAKER FOR LONG STORAGE	16
CLEAN AND MAINTENANCE	17
EXTERIOR CLEANING	17
INTERIOR CLEANING	17
ICE MAKING PARTS CLEANING	18
ICE MAKING ASSEMBLY SYSTEM CLEANING BY USING NU-CALGON NICKLE SAFE ICE-MACHINE CLEANER	19
CLEANING SUGGESTION	19
NORMAL TROUBLE SHOOTING	21
CORRECT DISPOSAL OF THIS PRODUCT	22

IMPORTANT SAFETY INFORMATION

When using electrical appliances basic safety precautions should be followed to reduce the risk of fire, electric shock, and injury to persons or property. Read all instructions before using any appliance.

-Use this appliance only for its intended purpose as described in this owner's manual. This icemaker must be properly installed in accordance with the installation instructions before it is used.

-This unit must be positioned so that the plug is accessible. Do not run cord over carpeting or other heat insulators. Do not cover the cord. Keep cord away from traffic areas, and do not submerge in water. No other appliance should be plugged into the same outlet. Be sure that the plug is fully inserted into the wall outlet.

-We do not recommend the use of extension cord as it may overheat and cause a risk of fire. If you must use an extension cord, use No.14AWG minimum size, and rated no less than 1875 watts.

-If the supply cord is damaged, it must be replaced by the manufacturer or its service agent or a similarly qualified person to avoid a hazard.

-Disconnect the main power supply plug from the socket when not in use for long term.

-Remove power plug or disconnect from the main supply before cleaning or servicing the appliance.

NOTE: *If for any reason this product requires service, we strongly recommend that a certified technician perform the service.*

-Never unplug the unit by pulling on the power cord. Always grasp the plug firmly and pull straight out from the outlet.

-Do not use your unit outdoors. Keep the unit away from direct sunlight and make sure that there is at least 6 inches of space between the back of your unit and wall. Keep the front free from obstructions. Keep the appliance's ventilation openings clear of obstruction.

-Do not tip the unit over as this will cause the machine to make irregular noises and make the ice-cube size abnormal. If the unit is tipped, it may also cause water leakage.

-If the unit is stored in a cool space or comes in contact with a cold environment, give it a few hours to warm up to room temperature before plugging it in.

-Do not use other liquid to make ice-cubes other than water.

-Do not clean your ice maker with flammable fluids. The fumes can create a fire hazard or explosion.

- **WARNING:** This appliance must be earthed and use the 110-120V/60Hz earthed power supply. Use the proper power source according to the nameplate.
- **WARNING:** Keep ventilation openings, in the appliance enclosure or in the built-in structure, clear of obstruction.
- **WARNING:** Do not damage the refrigerant circuit.
- **WARNING:** This appliance is not intended for use by persons (including children) with reduced physical, sensory, or mental capabilities, or lack of experience and knowledge, unless they have been given supervision or instruction concerning use of the

appliance by a person responsible for their safety.

- **WARNING:** Children should be supervised to ensure that they do not play with the appliance.
- **WARNING:** Do not store explosive substances such as aerosol cans with a flammable propellant in this appliance.
- **DANGER** – Risk of fire or explosion. Flammable refrigerant used. Do not use mechanical devices to defrost ice maker. Do not puncture refrigerant tubing.



- **CAUTION – Risk of fire or explosion. Flammable refrigerant used. Consult repair manual/owner’s guide before attempting to install or service this product. All safety precautions must be followed.**
- **CAUTION – Risk of fire or explosion. Dispose of property in accordance with federal or local regulations. Flammable refrigerant used.**
- **CAUTION-Risk of fire or explosion due to puncture of refrigerant tubing; Follow handling instructions carefully. Flammable refrigerant used.**
- **The ice maker should be installed in accordance with the safety standard for Refrigeration Systems, ASHRAE15. The ice maker should not be installed in corridors or hallways of public buildings.**
- **If the unit experiences problems or needs maintenance, the servicing or replacing of like components shall be done by factory authorized service personnel, so as to minimize the risk of possible ignition due to incorrect parts or improper service.**
- **WARNING: Keep ventilation openings, in the appliance enclosure or in the built-in structure, clear of obstruction.**
- **WARNING: This appliance is intended to be used in household and similar applications such as:**
 - staff kitchen areas in shops, offices and other working environments
 - farmhouses and by clients in hotels, motels and other residential type environments
 - bed and breakfast type environments
 - catering and similar non-retail applications

IMPORTANT:

The wires in this unit’s lead are colored in accordance with the following code:

Green or Green with a strip yellow:	Grounding
White:	Neutral
Black:	Live

- **To avoid a hazard due to instability of the appliance, it must be placed at an even or flat surface.**

SPECIFICATIONS

DIMENSIONS/CONNECTIONS

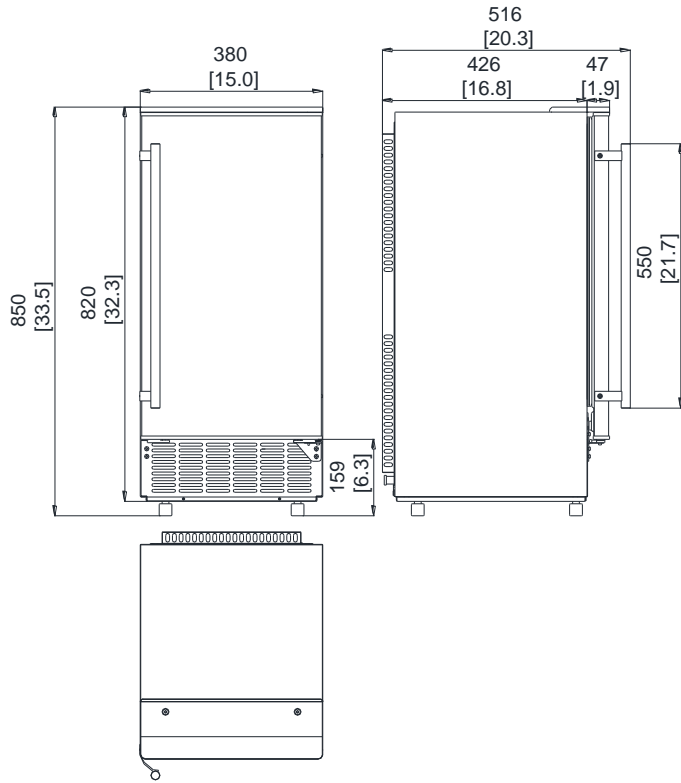

Rating

MODEL	DGUTICM01
POWER SUPPLY VOLTAGE	1Phase, 110-120/60Hz
CLAIMATE CLASS	10-40°C
ELECTRICAL PROTECTION CLASS	I
ICE MAKING RATING (Amps)	2.6Amp
ICE HARVEST RATING (Amps)	2.7Amp
ICE MAKING CAPACITY (KG/24H)	36kg/24Hour *
REFRIGERANT CHARGE	R290 2.83Oz / 80g
NET WEIGHT (lbs)	62 lbs
VESICANT	C ₅ H ₁₀
UNIT DIMENSIONS (W X D X H) (mm)	15x20.3x33.5
MAX ICE STORAGE CAPACITY (lbs)	24lbs
ACCESSORIES	SHOVEL, INSTALLATION KITS, HANDLE
CONNECTION	POWER CORD --- 18AWG WATER SUPPLY----6.35mm diameter DRAIN--- Φ16 SYLPHON BELLOWSS(REAR)
RUNNING CONDITIONS	ROOM TEMP 50-110 Fahrenheit WATER SUPPLY TEMP 41-95 Fahrenheit WATER SUPPLY PRESSURE 0.04-0.6 MPa

NOTE *: TESTED AT 70 Fahrenheit ROOM TEMPERATURE AND 50 Fahrenheit WATER TEMPERATURE.

GENERAL INFORMATION

1) Main Unit Construction

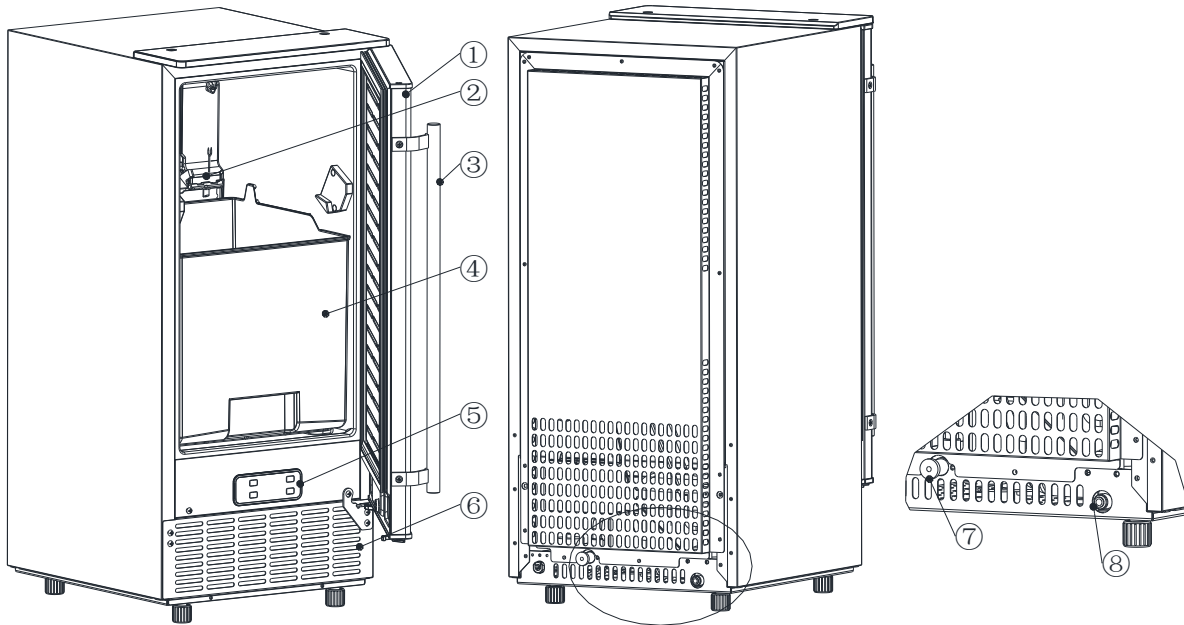

1. Door
2. Ice-making & its water tank assembly: Including ice-making evaporator, water tank, water pump and some detecting parts
3. Handle
4. Ice tank
5. Operation panel
6. Air outlet: Must keep the air circulate smoothly, hot air will blow out when unit running.
7. Water draining port: Normally the water draining port will be plugged with the cap. When the water needs to be drained, unplug the cap and connect the white drainpipe.
8. Water inlet port for water supply: Use to connect the water supply pipe.

Accessory: 2 meters long and white color water drainpipe

water quick connector of the water faucet

ø6.35mm diameter and white color water supply pipe (3 meters long) .

2) Ice-making and its water tank parts

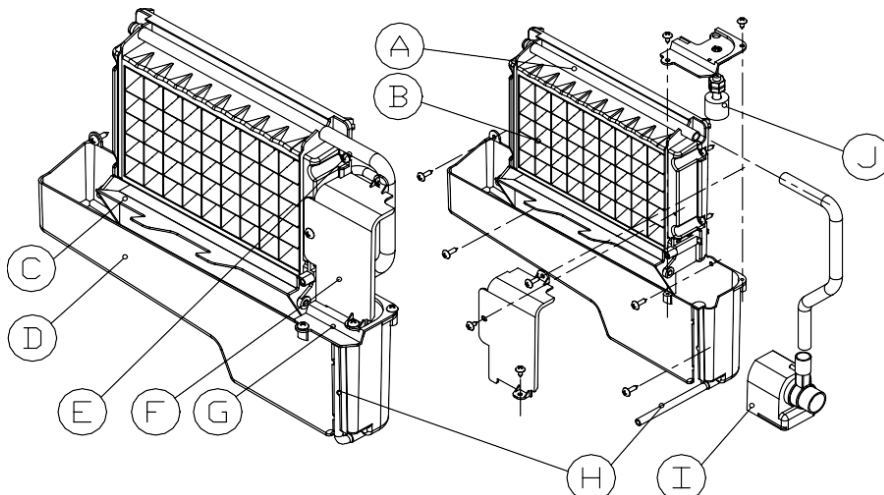

Water dividing pipe: With nine little holes, water will flow out from these little holes. If no water flows out, this piece can be disassembled and cleaned.

- A. Evaporator (ice-making module)
- B. Ice full detecting board: Use to detect if the inner cabinet is full of ice or not, and to check if the ice-harvest process is complete or not.
- C. Water tank
- D. Water supplying pipe
- E. Cover board on the right side of the evaporator
- F. Water level switch installing plate
- G. Water drainpipe of the water tank: When ice-making, this pipe should be clamped in the slot of the water tank wall; When draining, this pipe should be pulled out.
- H. Water pump
- I. Water level detecting switch

3) Operation panel

A. "TIMER/CLEAN" button: Quickly press this button once to enter the Timer Setting program. Press this button for more than 5 seconds to enter the Cleaning program.

B. "ON/OFF" button: When the unit is off, press this button to turn the unit on. During the Self-Cleaning program, or normal ice-making state press this button to turn the unit off immediately. If the unit is set with the Timer, press this button to cancel the Timer setting. When the unit is in the process of making ice, press this button for more than 5 seconds to force the unit switch to the ice harvesting process.

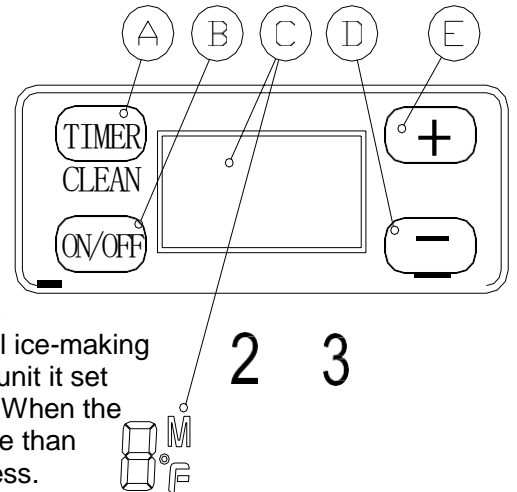

C. LCD Display Window (See below figure)

- 1.Environmental temperature and ice-making countdown display: The ice-making countdown time is displayed with an "M" to indicate such. The environmental temperature is displayed with an "F" to indicate such.
 - 2.Making ice and deice symbol display: The machine is making ice when this symbol rotates, and the machine is deicing when this symbol flashes.
 3. Automatic self-cleaning symbol display
 - 4.On/Off symbol display
 - 5.Error code display: When "E1" is displayed, this means the environmental temperature sensor is damaged. When "E2" is displayed, this means there is an ice-making anomaly or a refrigerant leak.
 - 6.Water flow in and water shortage display: The arrow flashing indicates that the machine is in the water. When the entire symbol is illuminated it indicates that the machine is low on water.
- D. & E. Plus (+) and Minus (-) buttons: Use to adjust the ice-making process duration length (the default setting is zero). Each press of the plus or minus button will increase or decrease the time by 1 minute.

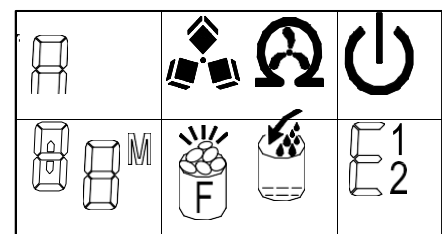

4)EXPLOSIVE DRAWING

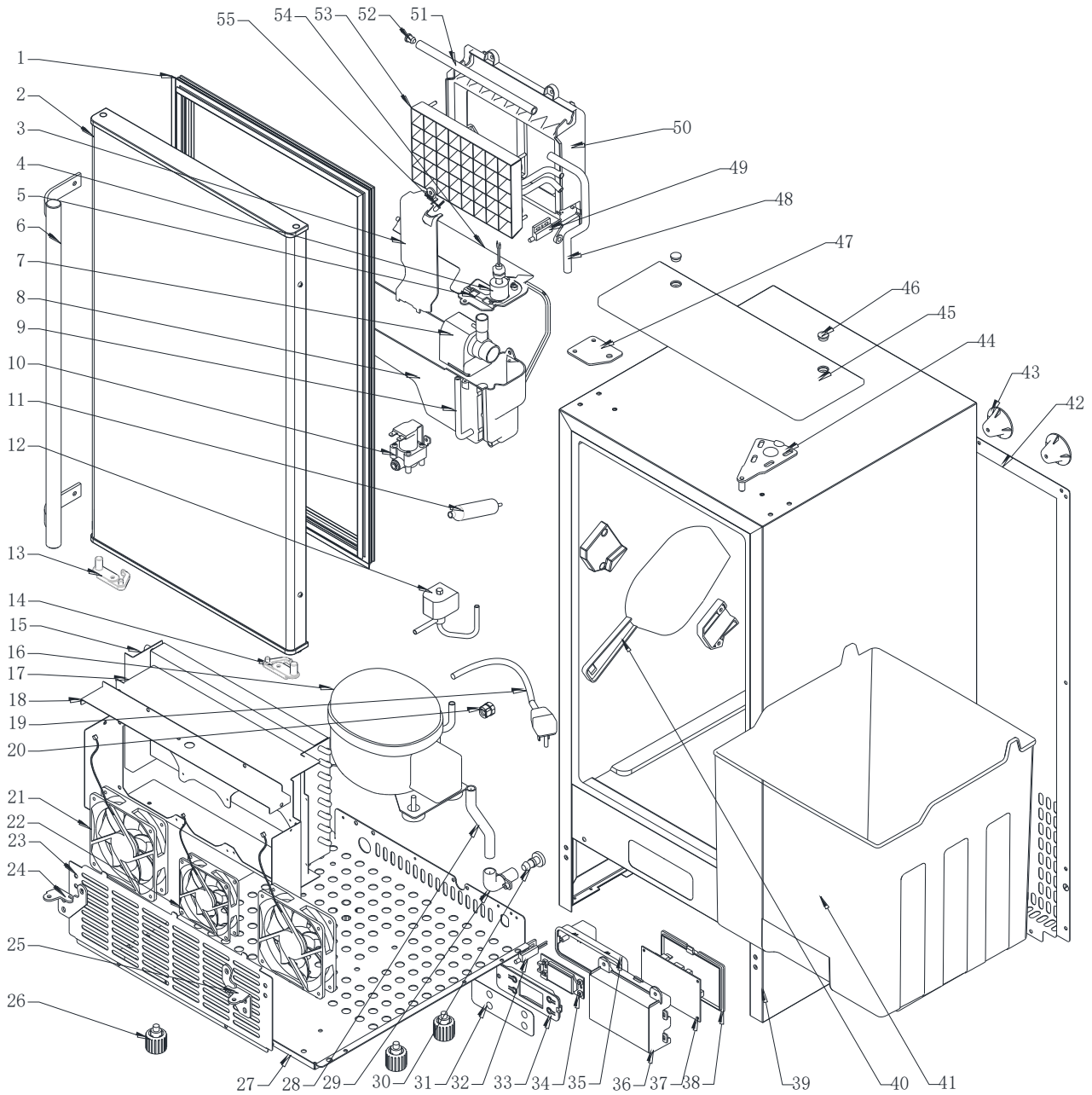

NO.	Part Name	Specifications	Qty
1	Door seal	PVC	1
2	Door	SUS & Foams	1
3	Water tank side cover	ABS White	1
4	Float switch	Electrical part DC5V	1
5	Water tank cover	ABS White	1
6	Handle	SUS	1
7	Pump	Electrical part AC115V	1
8	Water Tank	ABS White	1
9	Drain tube for water tank	Silicone tube, FDA	1
10	Water inlet solenoid	Electrical part DC12V	1
11	Filter Dryer	Copper and dryer	1
12	Solenoid valve for ice release	Electrical part AC115V	1
13	Left fix piece	POM	1 (accessory)

14	Right fix piece	POM	1
15	Condenser	Copper and aluminum	1
16	Compressor & accessory	Electrical part AC115V	1
17	Fan fix plate	Zinc-Plate sheet $\delta=0.8$	1
18	Fan fix cover plate	Zinc-Plate sheet $\delta=0.6$	1
19	Plug +Power cord	Electrical part AC115V	1
20	Strain relief bushing	PP black	1
21	Fan	Electrical part DC12V 120mm	2
22	Fan	Electrical part DC12V 90mm	1
23	Air outlet panel	SUS430 $\delta=0.8$	1
24	Left bottom hinge	SPCC $\delta=2.5$ mm Chrome Plated	1 (accessory)
25	Right bottom hinge	SPCC $\delta=2.5$ mm Chrome Plated	1
26	Adjusted foot	M8*30mm	4
27	Bottom plate	Zinc-Plate sheet $\delta=1.2$	1
28	Drain tube on liner	Silicone tube, FDA	1
29	Water drainage port	ABS Gray, FDA	1
30	Water drainage cap	Rubber Black	1
31	Operation panel paper	PET, thickness 0.25mm	1
32	Control switch for Led light	Electrical part DC5V	1 (assortative)
33	Operation panel PCB fix board	ABS Black	1
34	Operation panel PCB	Electrical part DC5V	1
35	Operation panel PCB box	ABS Black	1
36	Main PCB box	ABS 5V Black	1
37	Main PCB	Electrical part AC115V	1
38	Main PCB cover	ABS 5V Black	1
39	Foaming cabinet	Sheet metal +foams	1
40	Ice scoop	ABS White	1
41	Ice basket	PP White	1
42	Back-cover plate	Zinc-Plate sheet $\delta=0.6$	1
43	Back support column	PP black	4
44	Top hinge	SPCC $\delta=2.5$ mm Zinc-plated	1
45	Top cover	ABS Black	1
46	Screw hole cover	ABS Black	1
47	Fix plate	SPCC $\delta=2.5$ mm Zinc-plated	1
48	Water outlet tube form pump	Silicone tube, FDA	1
49	Magnet switch	Electrical part DC5V	1
50	Evaporator frame	ABS White	1
51	Water dividing pipe, eight holes	ABS White	1
52	Cap of the water dividing pipe	Silicone, FDA	1
53	Evaporator	Copper Nickle plated	1
54	Ice full detecting plate	ABS White	1
55	LED light	Electrical part DC5V white light	1

OPERATING PROCEDURES & MAINTENANCE

UNPACKING YOUR ICE MAKER

1. Remove the exterior and interior packaging. Check to ensure that all the accessories, including instruction manual, ice scoop, white water inlet pipe, 4-ways-to-2-ways water quick connector and the water draining pipe, etc., are inside. If any parts are missing, please contact our customer service.
2. Remove the tapes for fixing the door and inner cabinet, ice scoop, etc. Roughly clean the inner cabinet & ice scoop with wet cloth.
3. Put the ice maker on a level & flat floor, without direct sunlight or other sources of heat (i.e.: stove, furnace, radiator). Make sure that there is at least 50cm gap between the air outlet and the obstacles, and at least 5 cm between the wall.
4. Allow 4 hours for the refrigerant fluid to settle before plugging in the ice maker.
5. The appliance must be positioned so that the plug is accessible.

WARNING: Connect to potable (drinkable) water supply only.

DOOR REVERSING (Optional)

If you want the refrigerator door to open from the opposite side, you can reverse the door swing.

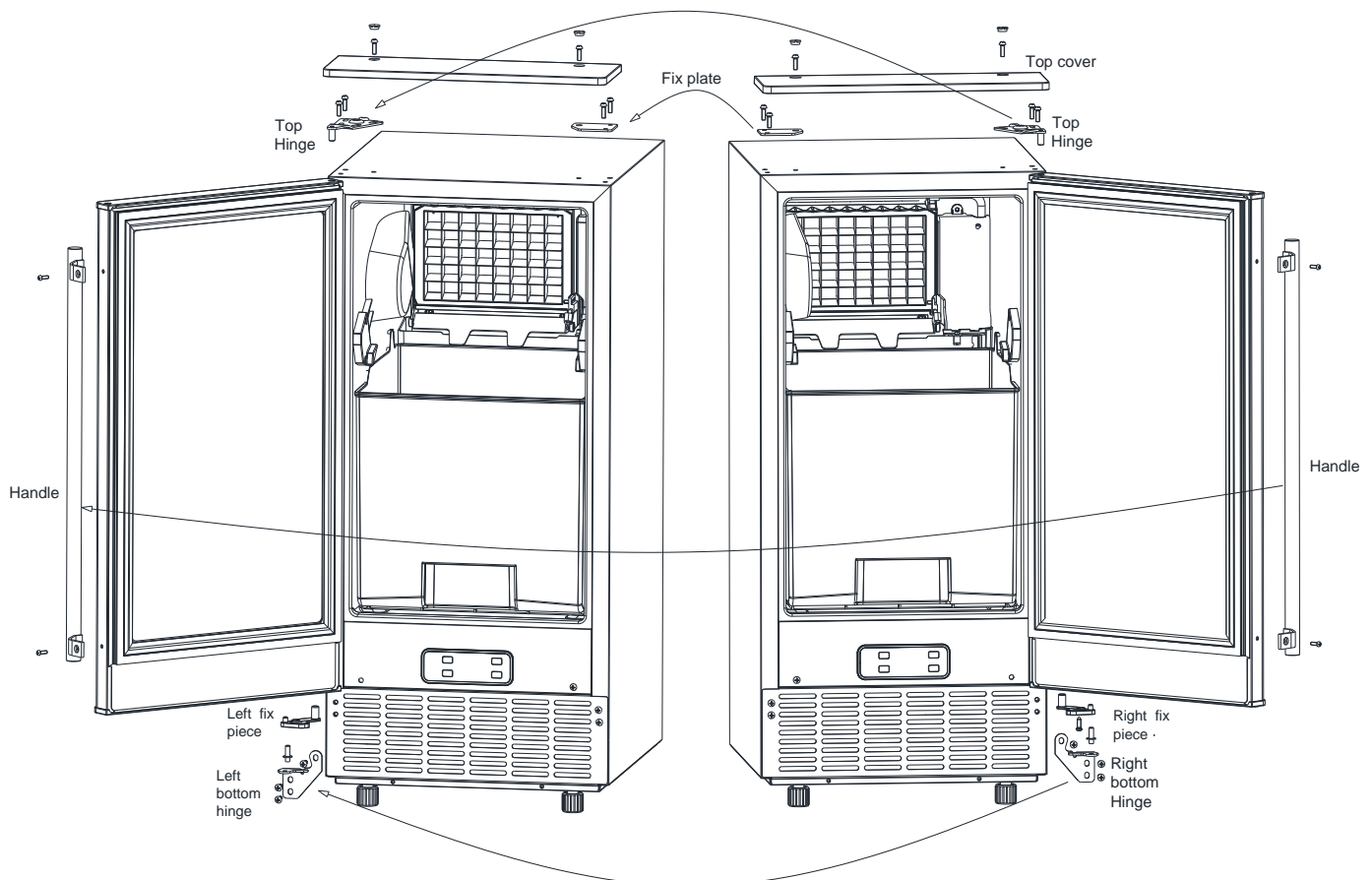

1. Ensure the unit unplugged before starting door reversal.
2. Remove the 2 screw hole cover on the top cover, then unscrew the 2 screw which is fixed in the top cover.
3. Remove the 2 screws from the top hinge and 2 screws from the fix plate.
4. Lift the door up and take off the door.
5. Set the freezer door on a non-scratch surface with the exterior up.

6. Unscrew the 2 screw on the handle, fix on the opposite side of the door. Remove the screw on the right fix piece, attach the left fix piece (from accessory bag) to the door.

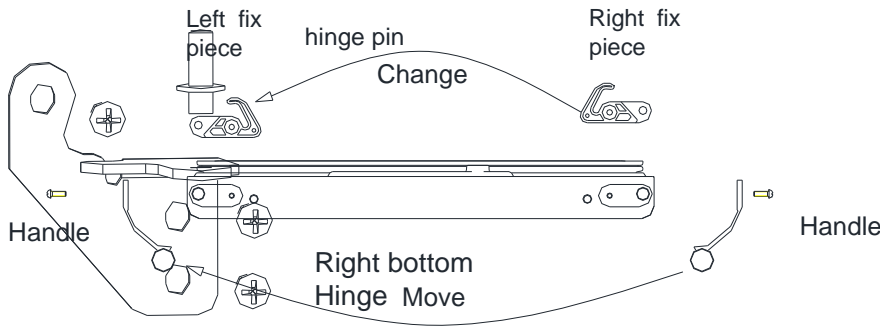

- 7. Remove the right bottom hinge by removing the 3 screws, then fix the 3 screw back without hinge.
- 8. Remove the hinge pin on the right bottom hinge and reinstall on the left bottom hinge.
- 9. Remove the 3 screws from the left side and fix the left bottom hinge on the unit.

- 10. Place the door on the left bottom hinge. With the magnetic gasket holding the door in place, make sure the door is aligned with the unit, and secure the top hinge on the left with 2 screws.
- 11. Open and close both the door several times to confirm the door is positioned correctly and the gasket is sealed well. If this is not the case, please adjust the door again.
- 12. Attach the Fix plate back on the right side. Fix the top cover with 2 screw, cover the screw hole with the Screw hole cover.
- 13. Wait at least 30 minutes before plugging in the refrigerator to allow the refrigerant to settle down. Then plug in the unit.

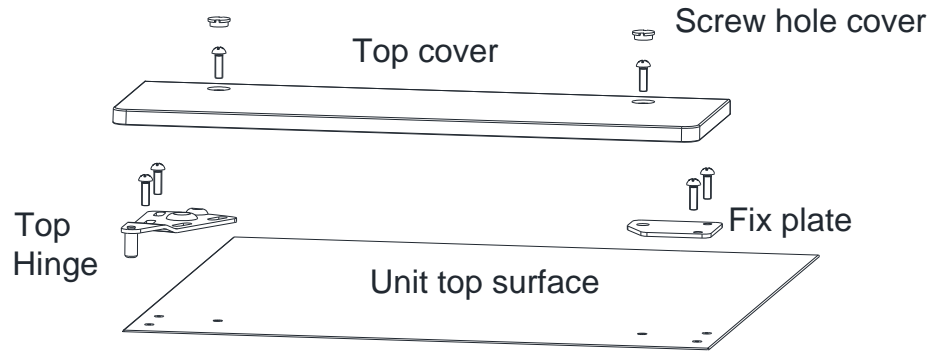
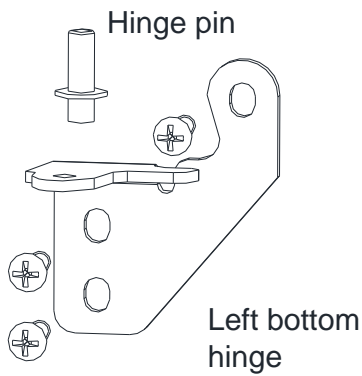

INSTALLATION LOCATION REQUIREMENT

- a) This unit is not for outdoor use. Keep the proper room temperature and inlet water temperature between 41-77 degrees Fahrenheit. Otherwise it will affect the ice making performance.
- b) This unit should not be located near any heat resource.
- c) The unit should be located on a firm & level foundation at normal countertop height.
- d) There must be at least 5CM clearance at rear side for connection and 25 CM clearance in front to open the door and keep good air circulation.
- e) Do not put anything on the top of the ice maker.

Installation Clearance

Top View (mm)

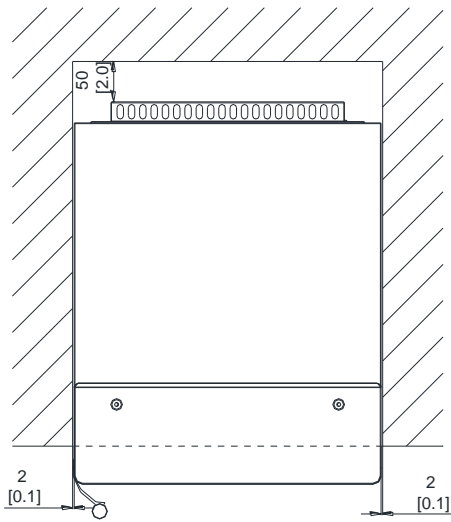

Side View (mm)

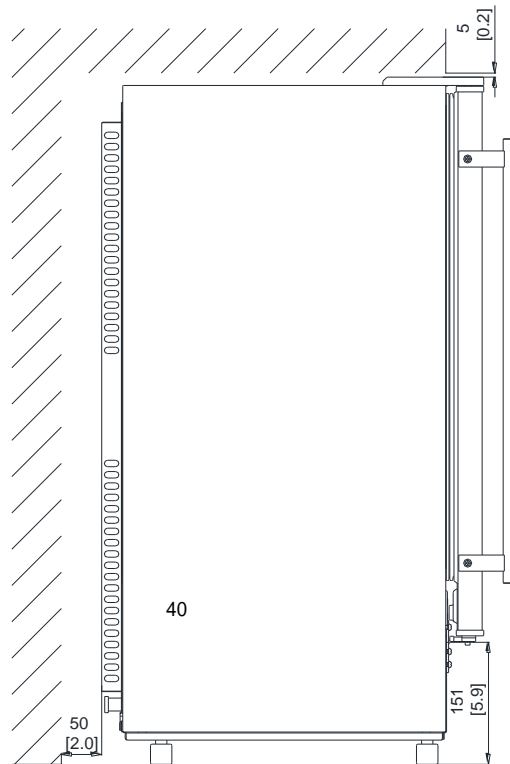

To ensure proper ventilation for your ice maker, the front of the unit must be completely unobstructed (at least 40CM free space). Allow about 2 mm clearance at rear, and 5 mm at top for proper air circulation. The installation should allow the ice maker to be pulled forward for servicing if necessary.

When installing the ice maker under a counter, follow the recommended spacing dimensions shown above. Place electrical and water supplies and drain fixtures in the recommended locations as shown.

Choose a well-ventilated area with temperatures above 50 degrees Fahrenheit and below 90 degrees Fahrenheit. This unit **MUST** be installed in an area protected from the elements, such as wind, rain, water spray or drips. The ice maker requires a continuous water supply with pressure 1-8 Bar as required in the specification table on Page 4. The temperature of the water feeding into the ice maker should be between 41 degrees Fahrenheit and 77 degrees Fahrenheit for proper operation.

ELECTRICAL REQUIREMENT & CONNECTIONS

WARNING: THIS UNIT MUST BE EARTHED.

Electrical Shock Hazard

Plug into a grounding wall outlet.

Never remove the ground prong.

Use separate power supply or receptacle.

Never use an adapter.

Never use an extension cord.

Failure to follow these instructions can result in death, fire, or electrical shock.

Before you move your ice maker into its final location, it is important to make sure you have the proper electrical connection.

It is recommended that a separate circuit, serving only your ice maker, be provided. Use receptacles that cannot be turned off by a switch or pull chain. If the supply cord or plug needs to be replaced, it should be done by a qualified service engineer.

This appliance requires a standard 110-120Volt, 60Hz electrical outlet with good grounding means.

Recommended grounding method

For your personal safety, this appliance must be properly grounded. This appliance is equipped with a power supply cord having a grounding plug. To minimize possible shock hazard, the cord must be plugged into a mating grounding-type wall receptacle, grounded in accordance with the National Electrical Code and local codes and ordinances. If a mating wall receptacle is not available, it is the personal responsibility of the customer to have a properly grounding wall receptacle installed by a qualified electrician.

CLEANING YOUR ICE MAKER BEFORE FIRST USING

Before using your ice maker, it is strongly recommended to clean it thoroughly.

1. Open the door to the ice chamber.
2. Clean with diluted detergent, warm water, and a soft cloth.
3. Repeatedly clean the water-contacting inner parts, you can pull the water tank's drainpipe (labeled "H" in illustration on Page 5) to drain the cleaned water in the water tank. Then, clean inner ice-storing cabinet and drain out all of the soiled water from the water drain port located at unit back (labeled "7" in the illustration on Page 5). Then, reinstall the water drainpipe back into the water tank and put the cap on the unit water drain port. If not reassembled correctly, the unit will not make the ice normally. **We suggest that you discard the ice-cubes made by the first ice-making cycle after cleaning for safety purposes.**
4. The outside of the ice maker should be cleaned regularly with a mild detergent solution and warm water.

WATER CONNECTION FOR YOUR ICE MAKER

Important: Be sure to use the new hose-sets supplied with the appliance to connect to water main. Old hose-sets should not be reused.

1. Connect the water supplying hose to the unit

First remove the tape on the water inlet port for water supply (indicated in the following illustration as “B”) located at unit back, then use your other hand’s finger to press the out circle. Insert the one end of the white water hose into the water inlet port, and push inward completely. Install the clipper, then water hose connection is completed.

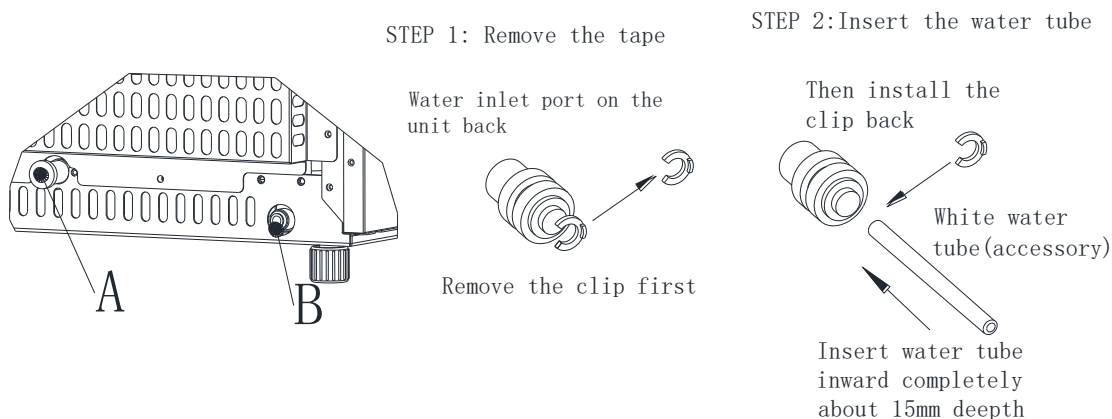

2. Connecting the water drainpipe

Pull out the black water drainage cap (labeled “A” in above illustration). Then, connect the white drainage pipe included in accessory pack to the main water drainage pipeline.

3. Connect the water hose to the water faucet of the water main supply system

First, install the supplied water quick-connector to the water faucet by screw thread; Second, remove the clipper from the water quick-connector. Insert the other end of the water hose into the quick-connector port completely, then install the clipper.

Important: The water pressure of main water supply system must be 0.04-0.6 MPa at least.

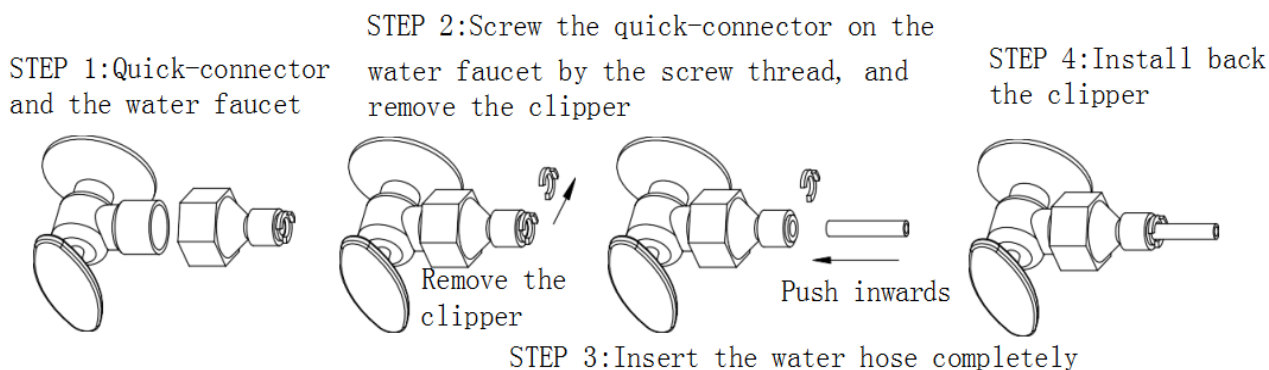





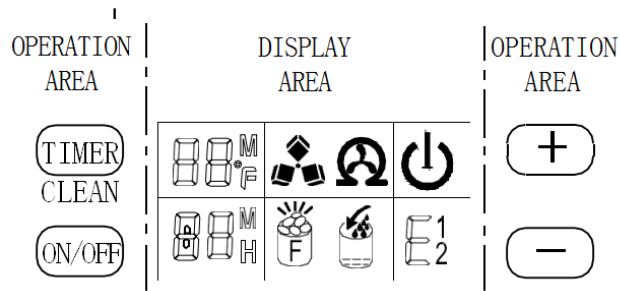

OPERATION YOUR UNIT

Operation button and display area diagram





Operation of the ice-making process

- To start the process, plug in the power plug and the Power symbol  will flash in the display window. Press the ON/OFF button on the control panel and the machine will start to make ice. When enough water has been added to reach the standard level on the water tank the Power symbol  will stop flashing in the display window. The Operation symbol  will rotate and the ambient temperature will be displayed in the upper left of the display window. "80F" means the ambient temperature is 80F, and so on. Several minutes later, when the ice-making process is coming to an end, the flashing numbers will be displayed in the ambient temperature display area. The flashing number "10M" means there is 10 minutes left in your ice making cycle.
- Each ice making cycle is finished with the machine entering a deicing process. The Operation symbol  will flash when entering into this part of the cycle. The arrow on the Water Intake symbol  will flash until the water reaches the standard level in the water tank needed for the deicing process. When the adequate amount of water in the tank has been met, the Water Intake symbol  will turn off. This indicates that the unit has entered the next ice making cycle. If the water cannot reach the standard level, the Water Intake symbol  will remain on and the unit will stop working. If this occurs, the unit needs to be restarted. Otherwise, it will start up automatically after 15 minutes.

Note: Each ice making cycle is around 11-20 minutes. The ice making time may vary according to the ambient temperature and the water temperature. Expect the first ice making cycle to be longer because of the high temperature of the water in the tank.

- Press the "+" and "-" buttons on the control panel to adjust the ice thickness. The number on the bottom left of the display window is the setting of the ice making time. The default is "0." Press the "+" button one time and the ice making time will increase by one minute. The longer the ice

cubes are in the ice-making process, the thicker they will be. Press the “ - ” button one time and the ice making time will decrease by one minute. The ice will be thinner if it is in the ice-making process for less time. Restart the machine it will go back to default “0.”

4. When the End of Cycle symbol  will light up and the machine will stop working when the ice-making process is complete.
5. **Shut down the unit:** After the unit has completed making ice, press the “ON/OFF” button on the control panel. The unit will shut down and enter standby mode. If you press "ON/OFF" longer than 5 seconds during ice making, then the unit enters the deicing process directly. This function can help remove the ice on the ice plate. Press the "ON/OFF" button to shut down the machine.
6. **Timing setting: Setting range:** 1-24 hours
 - Time shutdown: When the unit is running it can be set shutdown at a specific time.
 - Time on: When the unit is on standby mode, you can set the unit to turn on with ON-TIMER. Press the TIMER button. The default time is “1H,” or 1 hour, in the display window. Press the “+” button to adjust the timer to what you desire. Every time you press the “+” button, the timer will add 1 hour. Press the “-” button to reduce the timer. During the process of time adjustment, the “H” in the lower corner of the number will flash. After 5 seconds without any additional changes to your timer, the “H” letter will change from flashing to constant, meaning that the timer has been set.
 - In standby mode the unit will display “5H,” meaning that the unit will start automatically after 5 hours idle.
 - In ice making mode the unit will display “5H,” meaning that the machine will shut down automatically after 5 hours idle. T
 - The "H" in the display screen indicates that the machine currently has a timer set. You will see the time will descend (i.e. 5H, 4H, 3H, and so on) until the unit turns on or off depending on the mode it is currently set to.
 - How to cancel timing: When the unit has a timer, press and hold down the “TIMER” button. The timer will be canceled after the number on the screen and "H" are extinguished.
7. **Automatic self-cleaning program. The default cleaning time is 20 minutes.**
 - **Start the self-cleaning program:** After connecting all the water pipes, plug in the main power supply plug, then press the “TIMER CLEAN” button on control panel for more than 5 seconds. In the self-cleaning program, Self-Cleaning symbol  will rotate on the display screens. The time count down display will show 20M. The “CLEAN light will always be on during this period. The digit window will indicate the left time in the program. The water pump will run for 8 minutes and stop for 3 minutes and repeat. The total duration time is 20 minutes for one self-cleaning program. When the water pump stops and the self-cleaning program is complete, the water will supply the water tank automatically.
 - **Cancel the self-cleaning program:** It takes about 20 minutes to complete one self-cleaning program. When the program is over, the system will be in off-state automatically. You can press

the “ON/OFF” button on control panel to cancel the self-cleaning program by force.

8. Switching the Degrees Settings from Fahrenheit(°F) to Celsius(°C)

Press the “+” or “-” button for longer than 5 seconds and it will automatically switch.

WIRING DIAGRAM

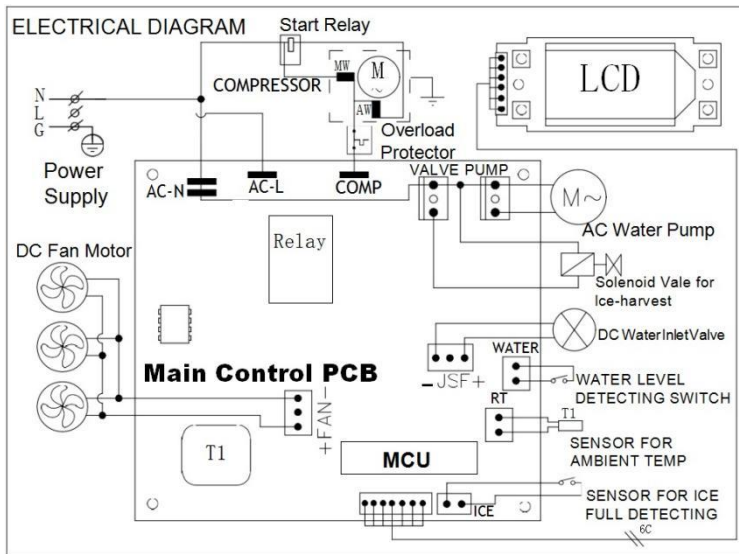

Normal Sounds

Your new ice maker may make sounds that you are not familiar with. Most of these sounds are normal. Hard surfaces like the floor, walls and cabinets can make the sounds seem louder than they are. The following describes the kinds of sounds that might be new to you and what may be making them.

- You will hear a swooshing sound when the water valve opens to fill the water tank for each cycle.
- Rattling noises may come from the flow of the refrigerant or the water line. Items stored on top of the ice maker can also make noises.
- The high-efficiency compressor may make a pulsating or high-pitched sound.
- Water running from the water tank to the evaporator plate may make a splashing sound.
- Water running from the evaporator to the water tank may make a splashing sound.
- As each cycle ends, you may hear a gurgling sound due to the refrigerant flowing in your icemaker.
- You may hear air being forced over the condenser by the condenser fan. During the harvest cycle, you may hear ice cubes falling into the ice storage bin.
- When you first start the ice maker, you may hear water running continuously. The ice maker is programmed to run a rinse cycle before it begins to make ice.

Preparing the Ice Maker for Long Storage

If the ice maker will not be used for a long time, or is to be moved to another place, it will be necessary to drain out all the water in the system.

1. Allow all the ice cubes to be ejected from the evaporator of the ice maker.
2. Turn off the unit and unplug the power cord.
3. Shut off the water supply at the main water supply.
4. Disconnect the water supply hose from the water inlet valve.
5. Pull out the water tank's drainpipe (labeled as "H" in the illustration on Page 5) to drain out all the water in the water tank. When all of the water has been drained out, you can reinstall the water drainpipe back into the water tank.
6. Then drain out all the water from the water drain port located at unit back (labeled "7" in the illustration on Page 5).

7. Disconnect the water drainpipe from the main drain pipeline or floor drain. Plug the drain cap back on.
8. Drop the door open to allow for circulation and prevent mold and mildew.
9. Leave water supply hose and power cord disconnected until ready to reuse.
10. Dry the interior & wipe the outside of the unit.
11. Put a plastic bag on the unit to avoid dust and dirt.

CLEANING & MAINTENANCE

WARNING:

- Before carrying out any cleaning or maintenance operations, unplug the ice maker from the main power supply. (EXCEPTION: Ice maker self-cleaning program).
- Do not use any alcohol or fume for cleaning/sanitization of the ice maker. It may cause cracks on the plastic parts.
- Ask a trained service person to check and clean the condenser at least once a year, to ensure that the unit works properly.
- This appliance must be cleaned by use of a water jet.

CAUTION

If the ice maker has been left unused for a long time before the next use it must be thoroughly cleaned. Follow carefully the instructions provided for cleaning or use of sanitizing solution. Do not leave any solution inside the ice maker after cleaning.

Periodic cleaning and proper maintenance will ensure efficiency, top performance, hygienic, and long life. The maintenance intervals listed are based on normal conditions. You may want to shorten the intervals if you have pets, or the unit is used outdoors, or there are other special considerations.

What shouldn't be done

Never keep anything in the ice storage bin that is not ice: objects like wine and beer bottles are not only unsanitary, but also food packaging may slip off and obstruct the drainpipe.

Exterior Cleaning

The door and cabinet may be cleaned with a mild detergent and warm water solution such as 28g of dish washing liquid mixed with 7.5L of warm water. Do not use solvent-based or abrasive cleaners. Use a soft sponge and rinse with clean water. Wipe with a soft clean towel to prevent water spotting.

Stainless-steel models can discolor when exposed to chlorine gas and should be cleaned. Clean stainless-steel models with a mild detergent and warm water solution and a damp cloth. Never use abrasive cleaning agents.

NOTICE: *Stainless-steel models exposed to chlorine gas and moisture, such as in areas with spas or swimming pools, may have some discoloration of stainless-steel. Discoloration from chlorine gas is normal.*

Interior Cleaning

For Ice Storage Bin

The ice storage bin should be sanitized occasionally. Clean the bin before the ice maker is used for the first time and reused after stopping for an extended period. It is usually convenient to sanitize the bin after the ice making system has been cleaned and the storage bin is empty.

1. Disconnect power from the unit.
2. Open the door and with a clean cloth, wipe down the interior with a sanitizing solution made of 28g of household bleach or chlorine and 7.5L of hot water (95°F to 115°F).
3. Rinse thoroughly with clear water. The wastewater will be drained out through the drainpipe.
4. Reconnect power to the unit.

The ice scoop should be washed regularly. Wash it just like any other food container.

! WARNING

DO NOT use solvent cleaning agents or abrasives on the interior. These cleaners may transmit taste to the ice cubes or damage or discolor the interior.

Ice Making Parts Cleaning

Periodically clean the main system of your icemaker.

1. Repeat above step to clean the water tank and other inner parts of the unit.
2. If there is no water flowing out from the water dividing pipe, or the water flowing is very low, please discharge this water dividing pipe to clean carefully. Clean each little hole on the water dividing pipe displayed in the illustration to the right. Make sure each hole is not clogged by something, then install back to the original location.

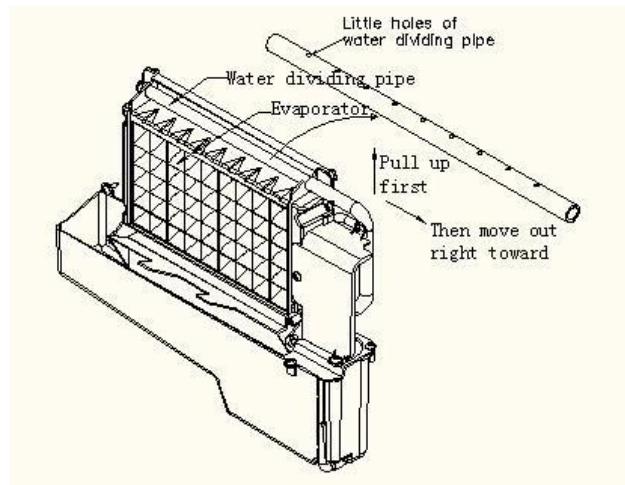

3. When there are ice cubes on the surface of the evaporator, but can't fall down easily, do not use a mechanical object to remove it by force; Only press the "ON/OFF" button for more than 5 seconds. The unit will enter the ice melting process. After some time, the big ice-cubes will fall down. Then, turn off the unit and unplug the power cord to clean the surface of the evaporator.

4. The water tank and the ice detecting plate is very important to keep your ice cube hygienic. Put a mixture of neutral cleaner and water into a clean water jet, then spray the inner surface of tank and ice detecting plate. Wipe these surfaces as far as possible with a clean cloth. And then, spray the surfaces with clean water, wiping with a dry clean cloth. Then, drain out the cleaned water in the water tank by pulling out the water tank's drainpipe (labeled "H" in the illustration on Page 5). When all of the cleaned water has been drained out, reinstall the water tank's drainpipe.

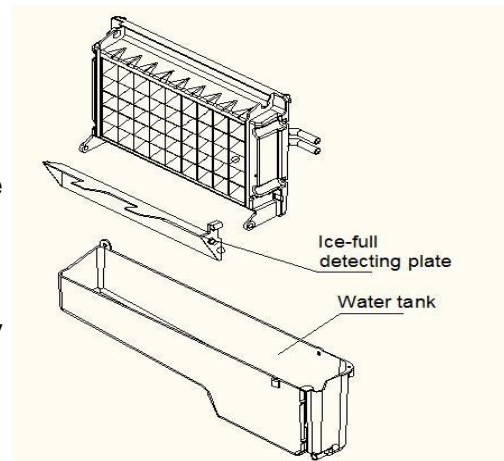

Suggestion: After cleaning the interior parts and reinstalling to its respective position, discard the first batch of ice for food safety purposes.

Ice Making Assembly System Cleaning by Using Nu-Calgon Nickle Safe Ice-machine Cleaner

Minerals that are removed from water during the freezing cycle will eventually form a hard, scaly deposit in the water system. Cleaning the system regularly helps remove the mineral scale buildup. How often you need to clean the system depends upon how hard your water is. With hard water of 4 to 5 grains/liter, you may need to clean the system as often as every 6 months.

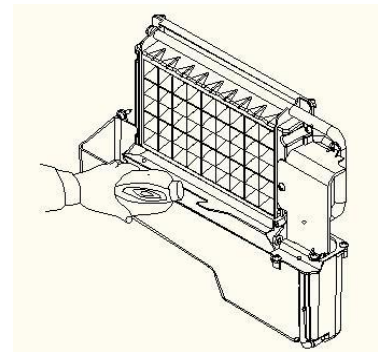

1. Turn off the ice maker. Keep the ice maker connected to the water supply and drainpipe but shut off the water faucet of main water supply.
2. Open the door and scoop out all the ice cubes. Either discard them or save them in an ice chest or cooler.



WARNING

Wear rubber gloves and safety goggles (and/or face shield) when handling Ice Machine Cleaner or sanitizer.

3. Make the cleaning solution by mixing the Nu-Calgon Nickle Safe Ice Machine Cleaner with water. Use a plastic or stainless-steel container with more than 4 liters of capacity. Mix 300 ml Nu-Calgon Nickle Safe Ice-machine Cleaner and 2.8 liters warm water at about 120°F-140°F. Then, divide them for 2 shares equally in 2 cups. It is better to keep the same temperature for each cup.
4. Check to be sure that the water tank's drainpipe has been installed properly in the slot of the tank wall. Then, pour one cup of Nickel-Safe Ice Maker Cleaning Solution into the water tank. Wait about for 5 minutes.
5. Turn on the power to the ice maker, then press the "TIMER CLEAN" button on the control panel for more than 5 seconds to enter the self-cleaning program. The water pump runs for 8 minutes and stops for 3 minutes and repeats this process for the total duration time of 30 minutes. During this process, the "CLEAN" light will and the digit window will indicate the remaining time.
6. After 30 minutes of one self-cleaning program has been completed, pull out the water

tank's drainpipe and drain the cleaning solution down to the lower ice storage bin. Shake the unit slightly to drain out all the cleaning solution completely. Then, reinstall the drain pipe to the slot of the water tank.

7. Repeat steps 4--6 to clean the ice making assembly system again.

WARNING

The ice machine cleaner contains acids.

DO NOT use or mix with any other solvent-based cleaner products.

Use rubber gloves to protect hands. Carefully read the material safety instructions on the container of the ice machine cleaner.

8. Open the water faucet of the main water supply. Let the water flow into the unit. Again, press the "TIMER CLEAN" button on the control panel for more than 5 seconds to enter the self-cleaning program. The water pump runs for 8 minutes and stops for 3 minutes and repeats this process for the total duration time of 30 minutes. During this process, the "CLEAN" light will always be on and the digit window will indicate the remaining time. Through this process, the machine will rinse the water dividing pipe, evaporator, water pump, silicone pipe, and water tank, etc..
9. After one self-cleaning program complete, pull out the water tank's drainpipe and drain the cleaning solution down to the lower ice storage bin. Shake the unit slightly to drain out all of the water completely. Then, reinstall the drainpipe to the water tank slot tightly.
10. Repeat the step 8-9 again for 2 times.
11. Following the above program to clean the ice storage bin.
12. With this special cleaning program finished, you can return to the regular ice making mode. We suggest that you discard the first batch of ice cube after cleaning for safety purposes.

Cleaning Suggestion

1) DAILY CLEANING

The ice shovel, door and the water dividing pipe should be cleaned per each day. At the end of every day, rinse the ice shovel and wipe the both sides of the door with a clean cloth.



2) SEMI-MONTHLY CLEANING

The ice shovel, ice bin, water tank, the ice detecting plate and the surface of the evaporator are to be cleaned semi-monthly according to interior cleaning program.

3) SEMI-ANNUAL CLEANING

All the components and surfaces exposed to water or ice cubes, like ice storage bin, water tank, door, evaporator, water pump, silicone tube, water dividing pipe, etc. should be cleaned **by Using Nu-Calgon Nickle Safe Ice-machine Cleaner** every 6 months. They should be cleaned by the serviceman according to ice making assembly system cleaning program.

NORMAL TROUBLE SHOOTING

Problem	Possible Cause	Solution
 indicator is on.	No water supply	Check the main water supply pressure or the water supply hose to ensure that it is not blocked, increasing the water pressure, or cleaning the hose if necessary.
	Floating ball of the water level detecting switch is blocked, can't be raised up	Clean the water tank and the water level detecting switch.
	Water flows out from the water tank	Place the unit on the level position, not on the slope.
	Water flows out from the water drainpipe of the water tank.	Pull out the pipe and reinstall to the slot of the water tank properly.
The unit starts to enter the ice making process, but no water is flowing into the unit, and the  Water Intake symbol flashes	Water supply hose breakdown, or water flows in very slowly.	Check the main water supply pressure or check the water supply hose to ensure it is not blocked, increasing the water pressure, or cleaning the hose if necessary.
Water pump is working, but no water is flowing out from the water dividing pipe	The little holes on the water dividing pipe are blocked.	Clean these little holes.
The transparency of the ice cube is not very good	Water quality is bad	Change the water supply or use a water filter to soften or filter the water.
Ice cube shape is irregular	Water quality is not good or the water tank is very dirty	Clean the water tank and refill it with new water.
	The little holes on the water dividing pipe is some blocked	Clean the water dividing pipe, making sure That all nine holes are unclogged
Ice cube is very thin	Ambient temperature is too high	Move the unit to a lower temperature space or lengthen the time of each ice making cycle.
	Air circulation around the unit is not good.	Make sure there is more than 20CM space between the unit back and front and the obstacle
Ice cube is too thick	Ambient temperature is too low	Reduce the time of each ice making cycle.
Ice making cycle is normal, but there are no ice cubes being produced	The ambient temperature, or water in water tank is too high	Move to a place with a temperature that is lower than 90 degrees Fahrenheit, and ensure your water temperature is low

Ice making cycle is normal, but there is no ice cube produced	Refrigerant leakage	Need the technical serviceman to maintain
	Cooling system tube is clogged	Need the technical service person to maintain

ERROR INDICATOR

- a) Ambient temp sensor breakdown Display E1 in digital window.
- b) The machine is not making ice or display window is reading as "E2."
- c) Magnetic control switch cutoff---- "Full" light will be on when plugging on or just turning on the unit. It will delete the breakdown display if this switch is electrically shorted.
- d) During the ice making process, press the "ON/OFF" button for more than 5 seconds. The unit will start to enter the ice harvesting program. After this program is complete, the unit will continue to enter the ice making process again.

CORRECT DISPOSAL OF THIS PRODUCT



This marking indicates that this product should not be disposed with other household wastes throughout the EU. To prevent possible harm to the environment or human health from uncontrolled waste disposal, recycle it responsibly to promote the sustainable reuse of material resources. To return your used device, please use the return and collection systems or contact the retailer where the product was purchased. They can take this product for environmentally safe recycling.



Manufacturer's 1-Year Limited Warranty

The manufacturer warrants that all parts and components are defect free in materials and workmanship for 1 year. This warranty is valid only in accordance with the conditions set forth below:

1. The warranty extends only to the original consumer purchaser and is not transferable. In addition, proof of purchase must be demonstrated.
2. This limited warranty is the only written or express warranty given by the manufacturer. Any implied warranty of merchantability or fitness for a particular purpose on this product is limited in duration to the duration of this warranty. Some states do not allow limitations on how long an implied warranty lasts, so the above limitation may not apply to you.
3. This warranty gives you specific legal rights. You may also have other rights which vary by state

Procedure for Replacement or Return within the 1 Year:

To return the product for replacement or refund within the 1 year, the original purchaser must pack the product securely and send it postage paid with a description of the reason for replacement or refund, proof of purchase, and include your order number on the package, to the following address:

Deco Chef
80 Carter Drive
Edison, NJ 08817

Other contact info

Phone: 844-413-2646
Customer Service Email: customerservice@decogear.com