



3.7QT Electric Oil-Free Digital Air Fryer - DCDAIRFR



USER MANUAL

Use little to no oil for healthier eating!

CONTENTS

| | |
|----------------------------------|---|
| Contents | 1 |
| Product/Introduction Layout..... | 2 |
| LCD Control Screen | 2 |
| Safety Precautions | 3 |
| Warnings | 3 |
| Caution | 4 |
| Electromagnetic Fields | 4 |
| Before First Use | 4 |
| Preparing First Use | 5 |
| Hot Air Frying | 5 |
| Air Frying Settings | 6 |
| Cleaning | 7 |
| Warranty | 8 |

Important:

Please read this manual carefully before using this appliance. Failure to fully read this manual may lead to accidental injury or damage to the appliance due to incorrect operation. Please adhere to and acknowledge all warnings and cautions listed in this manual

INTRODUCTION

Congratulations on purchasing your new Deco Chef 3.7QT Electric Oil-Free Digital Air Fryer! This air fryer provides an easier and healthier method to prepare your favorite ingredients and meals by using rapid, hot, cyclonic air. This hot air circulation cooks your food at all angles, so greasy and unhealthy oil is not necessary! Let's learn more about your new product below

PRODUCT LAYOUT

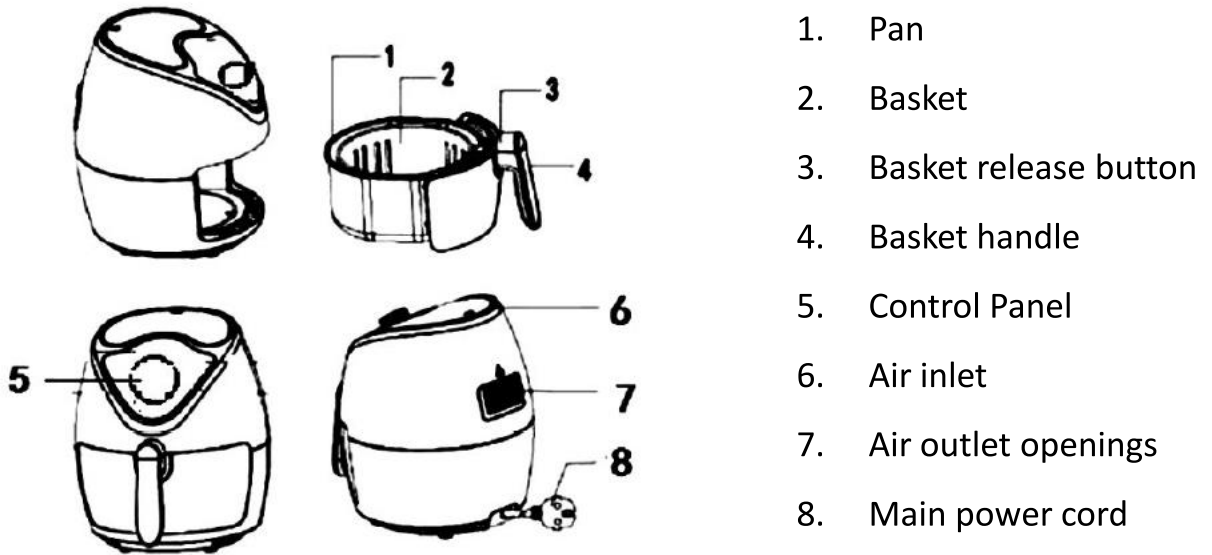

LCD Control Screen

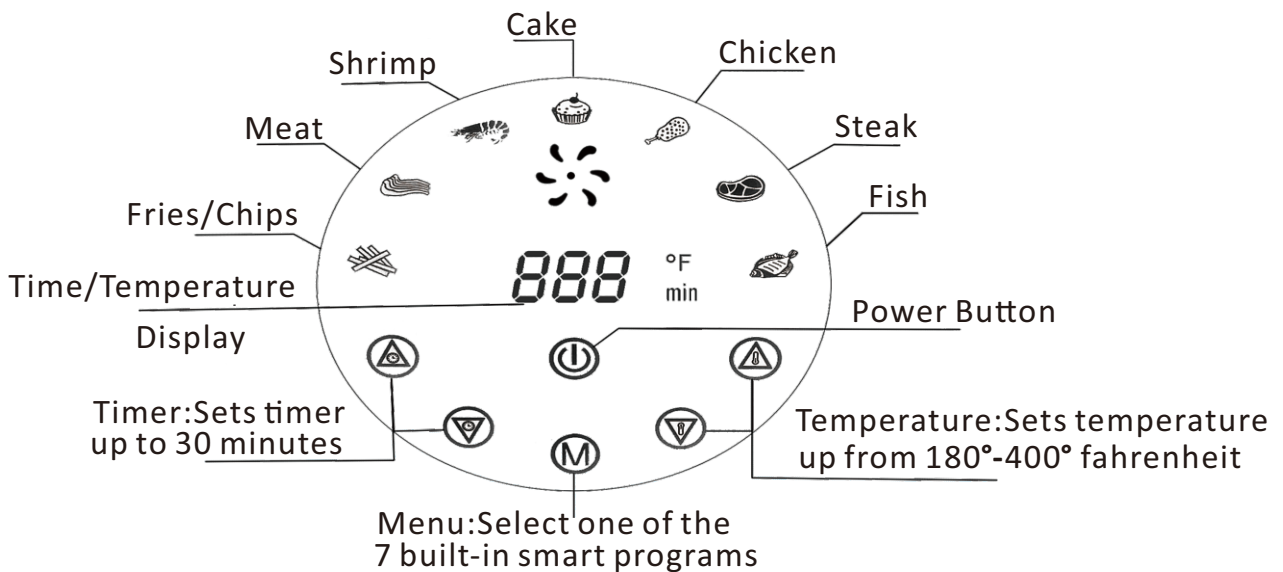

To cycle through the preset smart programs, keep pressing the "M" icon

You can adjust time or temperature by pressing the "△" or "▽" icons 2

SAFETY PRECAUTIONS

- DO NOT immerse the air fryer in water or rinse the outside of your air fryer with water
- AVOID liquid entering the appliance that can cause electric shock or short circuit the appliance
- Keep ALL INGREDIENTS IN THE BASKET to prevent contact with the heating elements
- DO NOT cover the air inlet and outlet when the appliance is being used
- Letting oil fill the Oil Catch Plate be a fire hazard – always empty regularly
- DO NOT touch the inside of the appliance when it is operating or shortly their after

WARNING

- Check if the voltage indicated on the appliance works with the voltage of your electrical output
- Do not use the appliance if there is any damage on the plug, cord, or other parts
- Do not receive repairs to the main power cord from unauthorized individuals
- Keep this appliance and the power cord out of reach from children
- Keep the power cord away from hot surfaces
- Do not plug this appliance into a ungrounded wall socket. Always make sure the plug is inserted into the wall socket properly
- Do not connect the appliance to an external timer switch
- Do not place the appliance on or near combustible/flammable martials such as a tablecloth or curtains
- Do not place the appliance against a wall or another appliance. Leave at least 4 inches of free space on all sides of the appliance
- Do not place anything on top of the appliance
- Do not use the appliance for any other purpose than what is described in this manual
- Do not let the appliance operate unattended

- During hot air frying, hot steam is released through the air outlet openings. Please avoid contact with the steam and the air outlets
- Be careful and be aware of the hot steam released when opening the basket
- Surfaces of the appliance may become hot during use
- **IMMEDIATELY UNPLUG THE APPLIANCE IF YOU SEE DARK SMOKE COMING OUT OF THE APPLIANCE. WAIT FOR THE SMOKE EMISSION TO STOP BEFORE REMOVING THE BASKET FROM THE APPLIANCE**

CAUTION

- Ensure the appliance is placed on a horizontal, even, and stable surface
- This appliance is designed for household use only. It may not be suitable to be safely used in environments such as staff kitchens, farms, motels, and other non-residential environments
- The guarantee is invalid if the appliance is used for professional or semi-professional purposes, or is used in a manner not listed in these instructions
- ALWAYS unplug the appliance when it is not in use
- This appliance needs approximately 30 minutes to cool down before it is accessible for safe cleaning

ELECTROMAGNETIC FIELDS (EMF)

This appliance complies with all standards regarding Electromagnetic fields (EMF). Under proper handling, this appliance will not cause harm to the human body based on available scientific evidence

BEFORE FIRST USE

1. Remove all packaging materials, stickers, and labels
2. Clean the basket and oil catch plate with hot water with minimal gentle soap and a non-abrasive sponge. These parts are also dishwasher safe
3. Wipe the inside and outside of the appliance with a cloth. You do not need to fill the oil catch plate with oil/frying fat as the appliance uses hot air to work

PREPARING FOR USE

Place the appliance on a stable, horizontal, and even surface. **DO NOT PLACE THE APPLIANCE ON A NON-HEAT RESISTANT SURFACE**

HOT AIR FRYING

1. Connect the main power cord into a grounded wall socket
2. Use the basket handle and pull the basket out of the air fryer
3. Place the ingredients/meal into the basket

NOTE: Do not exceed the MAX indication (see the SETTINGS section page 6) as it may effect the quality of the food

4. Slide the basket back into the air fryer
5. Set your cooking time and temperature by either pressing M to choose of the 7 presets or manually adjust time or temperature by pressing the “△” or “▽” icons
6. Once you have set your cooking time and temperature, press the power button again. A red dot surround by fan blades indicates the fryer has begin the cooking cycle. If there is no red dot, the cooker will go into standby mode

Add 3 minutes of cooking time if the appliance is cold.

7. Some recipes require your to shake up your food halfway through the cooking cycle. If needed, pull the basket out of the appliance by the handle and carefully shake it to mix contents. When finished, place it back into the air fryer to continue cooking
8. Check to make sure your meal is fully cooked
9. Empty the basket into a bowl or plate. Use a pair of tongs if necessary
10. Once your done cooking your meal, your air fryer is immediately ready for use again

AIR FRYER SETTINGS

This table below will help you select the correct settings for ingredients. *Please keep in mind that these settings are suggestions. The user must use their best judgement*

| Food | Temperature (F) | CookingTime (min) |
|-------------|-----------------|-------------------|
| Fries | 400 | 18-25 |
| Frozen Food | 215 | 10-15 |
| Wings | 390 | 15-20 |
| Steak | 355 | 12-15 |
| Chips | 400 | 25-30 |
| Fish | 355 | 15-18 |
| Chicken | 400 | 25-35 |
| Cake | 355 | 30-35 |
| Skewer | 390 | 15-20 |
| Pizza | 355 | 15-20 |
| Toast | 390 | 3-6 |
| Cookie | 355 | 12-15 |
| Reheat | 300 | 10 |

Note:For more detailed recipes, please refer to our included DECO CHEF recipe book.

Because the Rapid Air Technology heats the air inside the appliance instantly, briefly pulling the basket out of the air fryer to check progress barely disturbs the cooking process

Tips

- Smaller portions usually require a slightly shorter cooking time than larger portions
- A larger portion may require a slightly longer cook time
- Shaking your meal halfway through the cooking process optimizes the end result as more surface area gets evenly cooked
- Add *some* oil to fresh potatoes for crispy results, but be sure to fry them within a few minutes in the air fryer to prevent sogginess

- Do not prepare extremely greasy foods, such as sausages, in the air fryer
- Snacks that can be prepared in an oven can also be prepared in an air fryer
- The optimal amount for cooking crispy fries is 500 grams
- Place a baking tin or oven safe dish in the air fryer basket if you want to bake a cake or quiche. It's also helpful with fragile foods.
- You can also use the air fryer to reheat leftovers. To reheat, set the cooking temperature to 300F for ten minutes
- Remember, if the appliance is starting cold, be sure to add 3 minutes to your cooking time to allow the appliance to warm up

CLEANING

Clean the appliance after every use.

DO NOT clean the basket and the inside of the appliance using metal kitchen utensils or abrasive cleaning materials. This may damage the non-stick coating.

1. Unplug your air fryer
2. Wipe the outside of the appliance with a moist cloth
3. Clean the oil catch plate and basket with hot water, some soap, and a non-abrasive sponge
4. You can remove any leftover remnants with a degreasing liquid

NOTE: The oil catch plate is dishwasher safe

the inside of the appliance with a non-abrasive sponge. Clean the heating element with a soft cleaning brush to remove any leftover food stuck to the basket or oil catch plate, use hot water and clean soft cleaning brush to remove any food residue

When discarding of your air fryer, do not throw away with normal household waste. Please bring the appliance to a recycling center or other garbage collection point. Every step we take to prevent waste is a helpful contribution to improving our environment



Manufacturer's 1-Year Limited Warranty

The manufacturer warrants that all parts and components are defect free in materials and workmanship for 1 year. This warranty is valid only in accordance with the conditions set forth below:

1. The warranty extends only to the original consumer purchaser and is not transferable. In addition, proof of purchase must be demonstrated
2. This limited warranty is the only written or express warranty given by the manufacture. Any implied warranty of merchantability or fitness for a particular purpose on this product is limited in duration to the duration of this warranty. Some states do not allow limitations on how long an implied warranty lasts, so the above limitation may not apply to you
3. This warranty gives you specific legal rights. You may also have other rights which vary by state

Procedure for Replacement or Return within the 1 Year:

To return the product for replacement or refund within the 1 year, the original purchaser must pack the product securely and send it postage paid with a description of the reason for replacement or refund, proof of purchase, and include your order number on the package, to the following address:

Deco Chef
80 Carter Drive
Edison, NJ 08817